

ATP Industrial Grade CompactFlash Card Specification

Revision 3.5



Disclaimer:

ATP Electronics Inc. shall not be liable for any errors or omissions that may appear in this document, and disclaims responsibility for any consequences resulting from the use of the information set forth herein.

The information in this manual is subject to change without notice.

ATP general policy does not recommend the use of its products in life support applications where in a failure or malfunction of the product may directly threaten life or injury.

All parts of the ATP documentation are protected by copyright law and all rights are reserved. This documentation may not, in whole or in part, be copied, photocopied, reproduced, translated, or reduced to any electronic medium or machine-readable form without prior consent, in writing, from ATP Corporation.

The information set forth in this document is considered to be “Proprietary” and “Confidential” property owned by ATP.

Revision History

| Date | Version | Changes compared to previous issue |
|------------------------------|----------------|--|
| Aug. 25 th , 2010 | 2.3 | - Update 16GB capacity - Update certification and compliance - Update CHS Parameters - Update Type II CF card information |
| Jan. 26 th , 2011 | 3.0 | - Support S.M.A.R.T. command - StaticDataRefresh and EarlyRetirement Technology - Update performance - Update MTBF - Revise density |
| Feb. 25 th , 2011 | 3.1 | - Revise Figure 4-1: ATP S.M.A.R.T. tool operation - Revise UDMA mode 0~4 |
| Apr. 14 th , 2011 | 3.2 | - Add power failure protection feature |
| Sep. 30 th , 2011 | 3.3 | - Preliminary spec sheet of Industrial grade CF card with PowerProtector feature - Update new P/N and performance - Update ATP branch/office contact information |
| Dec. 16 th , 2011 | 3.31 | - Official released version - Revise Table 3-19: Ultra DMA Data Burst Timing Requirements - Revise environment specifications |
| Jan. 31 st , 2012 | 3.4 | - Add density 512MB/1GB/2GB |
| Mar. 14 th , 2012 | 3.5 | - Add TBW (Total Bytes Written) information - Revise StaticDataRefresh technology |

Your Ultimate Memory Solution!



Table of Contents

| | | |
|----------|--|-----------|
| 1 | ATP INDUSTRIAL GRADE COMPACTFLASH CARD OVERVIEW | 6 |
| 1.1 | ATP PRODUCT AVAILABILITY | 6 |
| 1.2 | INTRODUCTION | 7 |
| 1.3 | MAIN FEATURES | 7 |
| 1.4 | APPLICATION | 8 |
| 2 | PRODUCT SPECIFICATION..... | 9 |
| 2.1 | SYSTEM POWER REQUIREMENT..... | 9 |
| 2.2 | ENVIRONMENT SPECIFICATIONS | 9 |
| 2.3 | RELIABILITY | 10 |
| 2.4 | PERFORMANCE..... | 10 |
| 2.5 | CHS PARAMETERS | 11 |
| 2.6 | EXTRA FEATURES..... | 11 |
| 2.7 | GLOBAL WEAR LEVELING- LONGER LIFE EXPECTANCY..... | 12 |
| 2.8 | STATIC DATA REFRESH TECHNOLOGY – ASSURE DATA INTEGRITY | 12 |
| 2.9 | ATP POWER PROTECTOR – BUILT-IN POWER DOWN DATA PROTECTION..... | 12 |
| 2.10 | PHYSICAL DIMENSION SPECIFICATION | 13 |
| 2.11 | MECHANICAL FORM FACTOR (UNITS IN MM) | 13 |
| 2.12 | CERTIFICATION AND COMPLIANCE | 14 |
| 2.12.1 | <i>Certification table</i> | <i>14</i> |
| 3 | ELECTRICAL INTERFACE | 15 |
| 3.1 | PIN ASSIGNMENTS AND PIN TYPE..... | 15 |
| 3.2 | ELECTRICAL DESCRIPTION..... | 18 |
| 3.3 | ELECTRICAL SPECIFICATION | 25 |
| 3.3.1 | <i>Input Leakage Current.....</i> | <i>25</i> |
| 3.3.2 | <i>Input Characteristics</i> | <i>26</i> |
| 3.3.3 | <i>Output Drive Type</i> | <i>26</i> |
| 3.3.4 | <i>Output Drive Characteristics.....</i> | <i>27</i> |
| 3.3.5 | <i>Attribute Memory Read Timing</i> | <i>28</i> |
| 3.3.6 | <i>Configuration Register (Attribute Memory) Write Timing Specification.....</i> | <i>29</i> |
| 3.3.7 | <i>Common Memory Read Timing Specification</i> | <i>30</i> |
| 3.3.8 | <i>Common Memory Write Timing Specification.....</i> | <i>31</i> |
| 3.3.9 | <i>I/O Input (Read) Timing Specification.....</i> | <i>32</i> |
| 3.3.10 | <i>I/O Output (Write) Timing Specification.....</i> | <i>34</i> |
| 3.3.11 | <i>True IDE PIO Mode Read/Write Timing Specification.....</i> | <i>35</i> |
| 3.3.12 | <i>True IDE Multiword DMA Mode Read/Write Timing Specification.....</i> | <i>38</i> |
| 3.3.13 | <i>Ultra DMA Mode Read/Write Timing Specification</i> | <i>40</i> |
| 3.4 | CARD CONFIGURATION..... | 56 |
| 3.4.1 | <i>CompactFlash Storage Card Registers and Memory Space Decoding</i> | <i>56</i> |
| 3.4.2 | <i>Attribute Memory Function.....</i> | <i>58</i> |
| 3.4.3 | <i>Configuration Option Register (Base + 00h in Attribute Memory).....</i> | <i>59</i> |
| 3.4.4 | <i>Card Configuration and Status Register (Base + 02h in Attribute Memory)</i> | <i>59</i> |
| 3.4.5 | <i>Pin Replacement Register (Base + 04h in Attribute Memory).....</i> | <i>59</i> |
| 3.4.6 | <i>Socket and Copy Register (Base + 06h in Attribute Memory).....</i> | <i>60</i> |
| 3.5 | I/O TRANSFER FUNCTION | 61 |
| 3.6 | COMMON MEMORY TRANSFER FUNCTION | 62 |
| 3.7 | TRUE IDE MODE I/O TRANSFER FUNCTION | 63 |
| 3.8 | HOST CONFIGURATION REQUIREMENTS FOR MASTER/SLAVE OR NEW TIMING MODES | 65 |
| 3.9 | TERMINATION RESISTORS FOR ULTRA DMA OPERATION..... | 66 |

4 S.M.A.R.T. FUNCTION.....67

4.1 S.M.A.R.T. FEATURE.....67

4.2 S.M.A.R.T. FEATURE REGISTER VALUES.....67

4.3 S.M.A.R.T. DATA STRUCTURE.....68

4.4 ATP S.M.A.R.T. TOOL69



1 ATP Industrial Grade CompactFlash Card Overview

1.1 ATP Product Availability

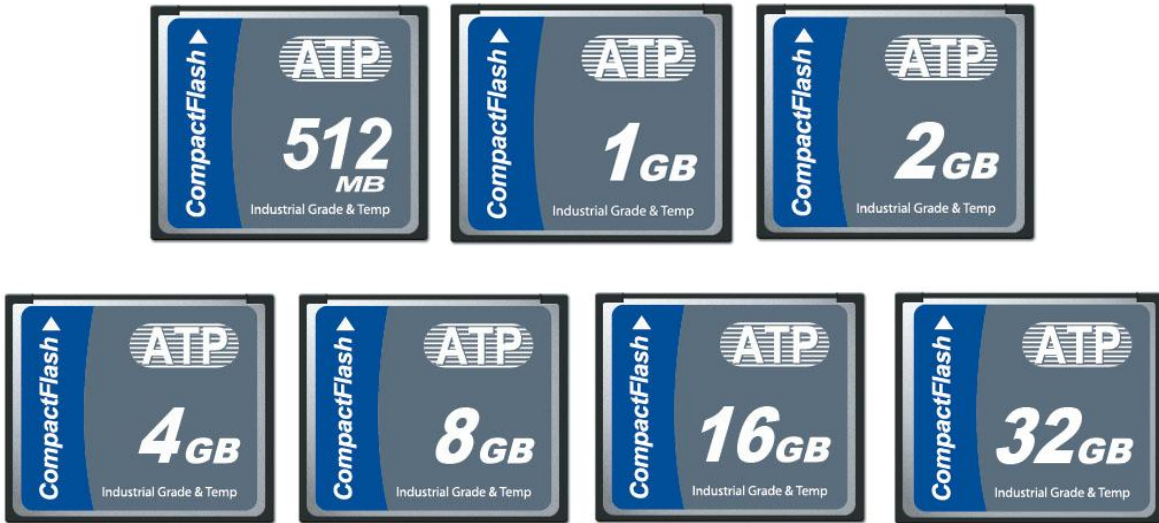

Figure 1-1: ATP Product Availability

Table 1-1: Capacities

| ATP P/N | CAPACITY |
|----------------|----------|
| AF512CFI-7ACXP | 512MB |
| AF1GCFI-7ACXP | 1GB |
| AF2GCFI-7ACXP | 2GB |
| AF4GCFI-7ACXP | 4GB |
| AF8GCFI-7ABXP | 8GB |
| AF16GCFI-7ABXP | 16GB |
| AF32GCFI-7AAXP | 32GB |

*Note: "P" stands for PowerProtector feature

1.2 Introduction

By utilizing SLC NAND flash memory and advanced Global Wear Leveling technology, the ATP Industrial Grade CompactFlash Card has enhanced endurance levels and a longer product lifespan. The ATP Industrial Grade CF card implements the StaticDataRefresh technology, which monitors the error bit levels during each read operation to ensure data integrity, and the EarlyRetirement technology prevents data loss from weak blocks.

The ATP Industrial Grade CF card has also incorporated the S.M.A.R.T. (Self-Monitoring, Analysis, and Reporting Technology) function which monitors various parameters of endurance and reliability, indicating activity that is out of the normal range. This information helps predict storage failure for preventative action.

Patent ATP PowerProtector technology is implemented in ATP industrial grade CF card to ensure a sufficient amount of backup power during power abnormalities to minimize the risk of data loss or firmware corruption.

1.3 Main Features

- **Host Interface:**
 - Compliance with CF specification 4.1
 - Pre-screened Single Level Cell (SLC) NAND flash memory
 - True IDE mode compatible:
Support PIO mode 0~6, MDMA mode 0~2, UDMA mode 0~4
- **High performance:**
 - Sequential read up to 51MByte/s (UDMA 4, Flash number x 2)
 - Sequential write up to 25MByte/s (UDMA 4, Flash number x 2)
 - Capacity: 512MB to 32GB
- **Industrial grade temp.:** -40°C to 85°C
- **Endurance:**
 - Enhanced endurance by *Global wear leveling* and bad block management
 - 13/24 bit BCH-ECC engines can correct up to 24 bit errors per 1,024 byte data
 - MTBF > 5,000,000 hours (@25°C)
 - Data reliability: Bit error rate 10E-15 (NAND flash)
 - Number of connector insertion/removals: >10,000
- **StaticDataRefresh technology to assure data integrity in read operations.**

- **PowerProtector, built-in power-down data protection**
- **S.M.A.R.T. function support for life time monitor**
- **Power saving mode (automatic sleep and wake-up mechanism)**

1.4 Application

ATP Industrial Grade CF cards are designed for demanding industrial applications, such as military/aerospace, automation, marine navigation, embedded systems, telecommunication equipment or networking and medical equipment where mission-critical data requires the highest level of reliability, durability, and data integrity.

2 Product Specification

2.1 System Power Requirement

Table2-1: System power table

| Parameter | Symbol | Min | Typ | Max | Unit | Remark |
|-------------------|-----------------------|-----------------|-----|-----|------|-------------------|
| Supply voltage | V _{CC} | 3.0 | 3.3 | 3.6 | V | |
| | | 4.5 | 5.0 | 5.5 | | |
| Standby Current | V _{CC} =3.3V | I _{SB} | - | - | mA | Average RMS value |
| Operating Current | | I _{CC} | - | 70 | | |
| Standby Current | V _{CC} =5.0V | I _{SB} | - | - | | |
| Operating Current | | I _{CC} | - | 100 | | |

2.2 Environment Specifications

Table2-2: Environment Specifications

| Type | | Standard |
|-------------------------------------|---------------|---|
| Temperature | Operating | -40°C to 85°C |
| | Non-Operating | -40°C to 85°C |
| Humidity | Storage | 40°C, 93% RH / 500hrs 85°C, 85%RH / 500hrs |
| Random Vibration test | Non-Operating | 10~2000Hz, 6Grms, 30min per axis |
| Drop test | Non-Operating | 150cm/Free fall |
| UV light exposure test (ISO 7816-1) | Non-Operating | 254nm, 15Ws/cm ² |

2.3 Reliability

Table 2-3: Reliability

| Type | Measurement |
|---------------------------|--|
| Number of insertions | 10,000 minimum |
| Endurance | 100,000 P/E cycles SLC NAND Flash cell endurance |
| TBW (Total Bytes Written) | 512MB 10 terabyte random write |
| | 1GB 20 terabyte random write |
| | 2GB 40 terabyte random write |
| | 4GB 80 terabyte random write |
| | 8GB 160 terabyte random write |
| | 16GB 320 terabyte random write |
| | 32GB 640 terabyte random write |
| MTBF (@ 25°C) | > 5,000,000 hours |

Note: Endurance for flash cards can be predicted based on the usage conditions applied to the device, the internal NAND flash cycles, the write amplification factor, and the wear leveling efficiency of the flash devices.

2.4 Performance

Table 2-4: Performance

| Model P/N | Seq. Read (KB/s) | Seq. Write (KB/s) | Random Read (KB/s) | Random Write (KB/s) |
|----------------|------------------|-------------------|--------------------|---------------------|
| AF512CFI-7ACXP | 24945 | 10742 | 24265 | 3408 |
| AF1GCFI-7ACXP | 29446 | 15597 | 28464 | 5200 |
| AF2GCFI-7ACXP | 30476 | 16075 | 29090 | 5624 |
| AF4GCFI-7ACXP | 50319 | 19266 | 44377 | 6285 |
| AF8GCFI-7ABXP | 51328 | 24945 | 44377 | 7261 |
| AF16GCFI-7ABXP | 51328 | 25190 | 44377 | 7402 |
| AF32GCFI-7AAXP | 50381 | 24945 | 43620 | 7553 |

*Note: Tested by HDBench 3.40 beta6 with 40MB file size. The performance may vary based on different testing environments.

2.5 CHS Parameters

Table 2-6 CHS Table

| SM2232AD with SLC | | | | | | |
|-------------------|------------|-----------|-------|---------|---------------|-------------------|
| Product density | Flash type | Cylinders | Heads | Sectors | Total sectors | Physical capacity |
| 512MB | 2K page | 991 | 16 | 63 | 998928 | 511451136 |
| 1GB | 2K page | 1966 | 16 | 63 | 1981728 | 1014644736 |
| 2GB | 2K page | 3900 | 16 | 63 | 3931200 | 2012774400 |
| 4GB | 8K page | 7785 | 16 | 63 | 7847280 | 4017807360 |
| 8GB | 8K page | 15538 | 16 | 63 | 15662304 | 8019099648 |
| 16GB | 8K page | 31045 | 16 | 63 | 31293360 | 16022200320 |
| 32GB | 8K page | 62041 | 16 | 63 | 62537328 | 32019111936 |

2.6 Extra Features

Table 2-5: Extra Features

| Type | Measurement |
|----------------|---|
| ESD Proof | Yes |
| RoHS Compliant | Yes |
| ESD Proof | IEC 61000-4-2: non-contact pad (Coupling plane discharge) +/- 8KV, non-contact pad (Air discharge) +/- 15KV |

2.7 Global Wear Leveling- Longer Life Expectancy

The program / erase cycle of each sector/page/block is finite. Writing constantly on the same spot will cause the flash to wear out quickly. Furthermore, bit errors are not proportioned to P/E cycles; sudden death may occur when the block is close to its P/E cycle limit. Then unrecoverable bit errors will cause fatal data loss (especially for system data or FAT).

Global wear leveling algorithm evenly distributes the P/E cycles of each block to minimize the possibility of one block exceeding its max P/E cycles before the rest. In return, the life expectancy of memory storage device is prolonged and the chance/occurrence of unrecoverable bit errors could be reduced.

2.8 StaticDataRefresh Technology – Assure Data Integrity

Over time the error bits accumulate to the threshold in the flash memory cell and eventually become uncorrectable despite using the ECC engine. In the traditional handling method, the data is moved to a different location in the flash memory; despite the corrupted data is beyond repaired before the transition.

To prevent data corruption, the CF card monitors the error bit levels in each read operation; when it reaches the preset threshold value, StaticDataRefresh is achieved by erasing and re-programming the data into the same block or into another block. After the re-programming operation is completed, the controller reads the data and compares the data/parity to ensure data integrity.

2.9 ATP PowerProtector – Built-in Power Down Data Protection

ATP PowerProtector technology ensures a sufficient amount of reserve power during any power abnormalities such as unstable voltages and power outages. PowerProtector's patent pending technology is a stand alone hardware design that does not require specific controllers or customized firmware. This feature provides greater flexibility during the design of a smaller form factor such as CompactFlash cards.

During a sudden power failure, the drive then draws power from PowerProtector's solid state capacitors for reserve power, which guarantee reliable drive operations. The solid state capacitors allow the flash to finish processing the last command or data.

SuperCap, the traditional power protection design, is well known for its sensitivity to temperature change and has a tendency of losing its capacitance and functionality at extreme temperatures. The average life span of SuperCap is less than two years; the capacitance will degrade over time and eventually fail to perform.

ATP PowerProtector surpasses the natural limitations of SuperCap designs by supporting wide temperature and an average life span of over five years without capacitance degradation. PowerProtector offers an advanced level of protection ensuring that data integrity is not compromised during a power failure scenario, and preserves critical data in mission critical applications.

2.10 Physical Dimension Specification

Table 2-7: Physical Specifications

| Type | | Measurement |
|---------|-----------|-----------------|
| Type I | Length | 36.4mm ± 0.15mm |
| | Width | 42.8mm ± 0.10mm |
| | Thickness | 3.3mm ± 0.10mm |
| | Weight | 9.0 g typical |
| Type II | Length | 36.4mm ± 0.15mm |
| | Width | 42.8mm ± 0.10mm |
| | Thickness | 5.0mm Max |
| | Weight | 9.0 g typical |

2.11 Mechanical Form Factor (Units in MM)

Figure 2-1: ATP CompactFlash Card Physical Dimensions

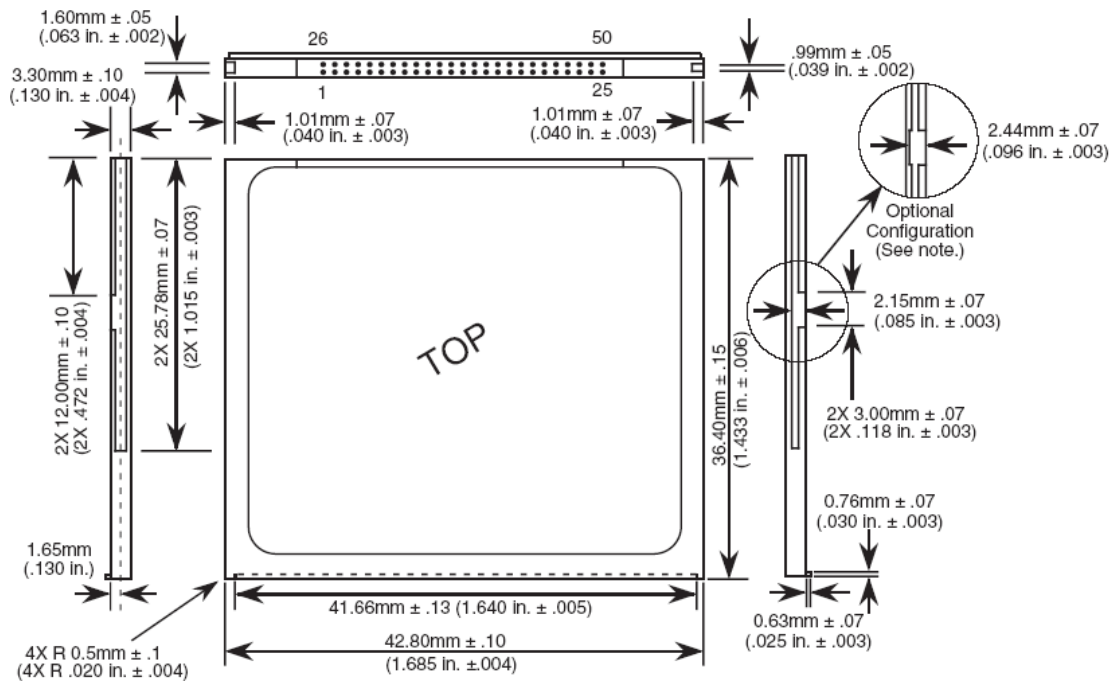

Note: The optional notched configuration was shown in the CF Specification Rev. 1.0. In specification Rev. 1.2, the notch was removed for ease of tooling. This optional configuration can be used but it is not recommended.

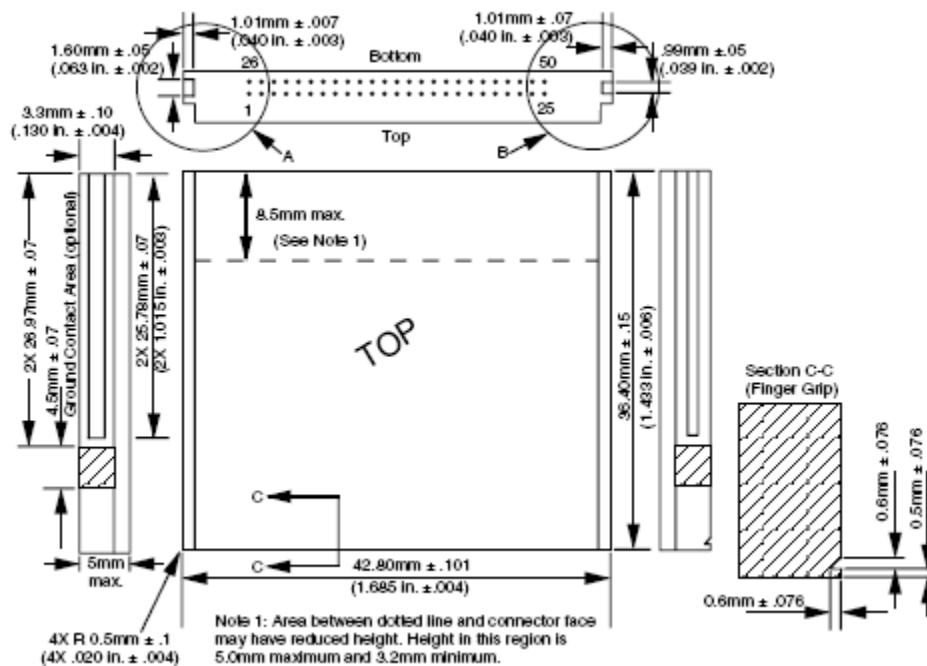



Type II

2.12 Certification and compliance

2.12.1 Certification table

Table 2-8: Certification table

| Mark/Approval | Documentation | Certification |
|---|--|---------------|
|  | The CE marking (also known as CE mark) is a mandatory conformance mark on many products placed on the single market in the European Economic Area (EEA). The CE marking certifies that a product has met EU consumer safety, health or environmental requirements. CE stands for Conformité Européenne, "European conformity" in French. | Yes |
|  | FCC Part 15 Class B was used for Evolution of United States (US) Emission Standards for Commercial Electronic Products, The United States (US) covers all types of unintentional radiators under Subparts A and B (Sections 15.1 through 15.199) of FCC 47 CFR Part 15, usually called just FCC Part 15 | Yes |
|  | RoHS is the acronym for Restriction of Hazardous Substances. RoHS, also known as Directive 2002/95/EC, originated in the European Union and restricts the use of specific hazardous materials found in electrical and electronic products. All applicable products in the EU market after July 1, 2006 must pass RoHS compliance. For the complete directive, see Directive 2002/95/EC of the European Parliament. | Yes |

3 Electrical Interface

3.1 Pin Assignments and Pin Type

The host is connected to the CompactFlash Card using a standard 50-pin connector. The connector in the host consists of two rows of 25 male contacts each on 50 mil (1.27 mm) centers.

The signal/pin assignments are listed in Table 3-1. Low active signals have a “-” prefix. Pin types are Input, Output or Input/Output. Section 3.3 defines the DC characteristics for all input and output type structures.

Table 3-1: Pin Assignments and Pin Type

| PC Card Memory Mode | | | | PC Card I/O Mode | | | | True IDE Mode ¹³ | | | |
|---------------------|-------------|----------|---------------------|------------------|-------------|----------|---------------------|-----------------------------|------------------|----------|--------------|
| Pin | Signal Name | Pin Type | In, Out Type | Pin | Signal Name | Pin Type | In, Out Type | Pin | Signal Name | Pin Type | In, Out Type |
| 1 | GND | | Ground | 1 | GND | | Ground | 1 | GND | | Ground |
| 2 | D03 | Ground | I1Z,OZ ₃ | 2 | D03 | I/O | I1Z,OZ ₃ | 2 | D03 | I/O | I1Z,OZ3 |
| 3 | D04 | I/O | I1Z,OZ ₃ | 3 | D04 | I/O | I1Z,OZ ₃ | 3 | D04 | I/O | I1Z,OZ3 |
| 4 | D05 | I/O | I1Z,OZ ₃ | 4 | D05 | I/O | I1Z,OZ ₃ | 4 | D05 | I/O | I1Z,OZ3 |
| 5 | D06 | I/O | I1Z,OZ ₃ | 5 | D06 | I/O | I1Z,OZ ₃ | 5 | D06 | I/O | I1Z,OZ3 |
| 6 | D07 | I/O | I1Z,OZ ₃ | 6 | D07 | I/O | I1Z,OZ ₃ | 6 | D07 | I/O | I1Z,OZ3 |
| 7 | -CE1 | I | I3U | 7 | -CE1 | I | I3U | 7 | -CS0 | I | I3Z |
| 8 | A10 | I | I1Z | 8 | A10 | I | I1Z | 8 | A10 ² | I | I1Z |
| 9 | -OE | I | I3U | 9 | -OE | I | I3U | 9 | -ATA SEL | I | I3U |
| 10 | A09 | I | I1Z | 10 | A09 | I | I1Z | 10 | A09 ² | I | I1Z |
| 11 | A08 | I | I1Z | 11 | A08 | I | I1Z | 11 | A08 ² | I | I1Z |
| 12 | A07 | I | I1Z | 12 | A07 | I | I1Z | 12 | A07 ² | I | I1Z |
| 13 | VCC | | Power | 13 | VCC | | Power | 13 | VCC | | Power |
| 14 | A06 | I | I1Z | 14 | A06 | I | I1Z | 14 | A06 ² | I | I1Z |
| 15 | A05 | I | I1Z | 15 | A05 | I | I1Z | 15 | A05 ² | I | I1Z |
| 16 | A04 | I | I1Z | 16 | A04 | I | I1Z | 16 | A04 ² | I | I1Z |
| 17 | A03 | I | I1Z | 17 | A03 | I | I1Z | 17 | A03 ² | I | I1Z |
| 18 | A02 | I | I1Z | 18 | A02 | I | I1Z | 18 | A02 | I | I1Z |
| 19 | A01 | I | I1Z | 19 | A01 | I | I1Z | 19 | A01 | I | I1Z |
| 20 | A00 | I | I1Z | 20 | A00 | I | I1Z | 20 | A00 | I | I1Z |
| 21 | D00 | I/O | I1Z,OZ ₃ | 21 | D00 | I/O | I1Z,OZ ₃ | 21 | D00 | I/O | I1Z,OZ3 |
| 22 | D01 | I/O | I1Z,OZ ₃ | 22 | D01 | I/O | I1Z,OZ ₃ | 22 | D01 | I/O | I1Z,OZ3 |
| 23 | D02 | I/O | I1Z,OZ ₃ | 23 | D02 | I/O | I1Z,OZ ₃ | 23 | D02 | I/O | I1Z,OZ3 |

| 24 | WP | O | OT3 | 24 | -IOIS16 | O | OT3 | 24 | -IOIS16 | O | ON3 |
|---------------------|---|----------|--------------|------------------|---|----------|--------------|-----------------------------|---|----------|--------------------------|
| PC Card Memory Mode | | | | PC Card I/O Mode | | | | True IDE Mode ¹³ | | | |
| Pin | Signal Name | Pin Type | In, Out Type | Pin | Signal Name | Pin Type | In, Out Type | Pin | Signal Name | Pin Type | In, Out Type |
| 25 | -CD2 | O | Ground | 25 | -CD2 | O | Ground | 25 | -CD2 | O | Ground |
| 26 | -CD1 | O | Ground | 26 | -CD1 | O | Ground | 26 | -CD1 | O | |
| 27 | D11 ¹ | I/O | I1Z,OZ 3 | 27 | D11 ¹ | I/O | I1Z,OZ 3 | 27 | D11 ¹ | I/O | I1Z,OZ3 |
| 28 | D12 ¹ | I/O | I1Z,OZ 3 | 28 | D12 ¹ | I/O | I1Z,OZ 3 | 28 | D12 ¹ | I/O | I1Z,OZ3 |
| 29 | D13 ¹ | I/O | I1Z,OZ 3 | 29 | D13 ¹ | I/O | I1Z,OZ 3 | 29 | D13 ¹ | I/O | I1Z,OZ3 |
| 30 | D14 ¹ | I/O | I1Z,OZ 3 | 30 | D14 ¹ | I/O | I1Z,OZ 3 | 30 | D14 ¹ | I/O | I1Z,OZ3 |
| 31 | D15 ¹ | I/O | I1Z,OZ 3 | 31 | D15 ¹ | I/O | I1Z,OZ 3 | 31 | D15 ¹ | I/O | I1Z,OZ3 |
| 32 | -CE2 ¹ | I | I3U | 32 | -CE2 ¹ | I | I3U | 32 | -CS1 ¹ | I | I3Z |
| 33 | -VS1 | O | Ground | 33 | -VS1 | O | Ground | 33 | -VS1 | O | Ground |
| 34 | -IORD HSTROBE ⁹ HDMARDY ¹⁰ | I | I3U | 34 | -IORD HSTROBE ⁹ HDMARDY ¹⁰ | I | I3U | 34 | -IORD ⁶ HSTROBE ⁷ HDMARDY ⁸ | I | I3Z |
| 35 | -IOWR STOP ^{9,10} | I | I3U | 35 | -IOWR STOP ^{9,10} | I | I3U | 35 | -IOWR ⁶ STOP ^{7,8} | I | I3Z |
| 36 | -WE | I | I3U | 36 | -WE | I | I3U | 36 | -WE ³ | I | I3U |
| 37 | READY | O | OT1 | 37 | -IREQ | O | OT1 | 37 | INTRQ | O | OZ1 |
| 38 | VCC | | Power | 38 | VCC | | Power | 38 | VCC | | Power |
| 39 | -CSEL ⁴ | I | I2Z | 39 | -CSEL ⁴ | I | I2Z | 39 | -CSEL | I | I2U |
| 40 | -VS2 | O | OPEN | 40 | -VS2 | O | OPEN | 40 | -VS2 | O | OPEN |
| 41 | RESET | I | I2Z | 41 | RESET | I | I2Z | 41 | -RESET | I | I2Z |
| 42 | -WAIT -DDMARDY ⁹ DSTROBE ¹⁰ | O | OT1 | 42 | -WAIT -DDMARDY ⁹ DSTROBE ¹⁰ | O | OT1 | 42 | IORDY ⁶ -DDMARDY ⁷ DSTROBE ⁸ | O | ON1 OT1 ¹² |
| 43 | -INPACK -DMARQ ¹¹ | O | OT1 | 43 | -INPACK -DMARQ ¹¹ | O | OT1 | 43 | DMARQ | O | OZ1 |
| 44 | -REG -DMARQ ¹¹ | I | I3U | 44 | -REG -DMARQ ¹¹ | I | I3U | 44 | -DMACK ⁵ | I | I3U |
| 45 | BVD2 | O | OT1 | 45 | -SPKR | I/O | OT1 | 45 | -DASP | I/O | I1U,ON 1 |
| 46 | BVD1 | O | OT1 | 46 | -STSCHG | I/O | OT1 | 46 | -PDIAG | I/O | I1U,ON 1 |
| 47 | D08 ¹ | I/O | I1Z,OZ 3 | 47 | D08 ¹ | I/O | I1Z,OZ 3 | 47 | D08 ¹ | I/O | I1Z,OZ3 |
| 48 | D09 ¹ | I/O | I1Z,OZ 3 | 48 | D09 ¹ | I/O | I1Z,OZ 3 | 48 | D09 ¹ | I/O | I1Z,OZ3 |
| 49 | D10 ¹ | I/O | I1Z,OZ 3 | 49 | D10 ¹ | I/O | I1Z,OZ 3 | 49 | D10 ¹ | I/O | I1Z,OZ3 |
| 50 | GND | | Ground | 50 | GND | | Ground | 50 | GND | | Ground |

Notes:

- 1) These signals are required only for 16 bit accesses and not required when installed in 8 bit systems. Devices should allow for 3-state signals not to consume current.
- 2) The signal should be grounded by the host.
- 3) The signal should be tied to VCC by the host.
- 4) The -CSEL signal is ignored by the card in PC Card modes. However, because it is not pulled up on the card in these modes, it should not be left floating by the host in PC Card modes. In these modes, the pin should be connected by the host to PC Card A25 or grounded by the host.
- 5) If DMA operations are not used, the signal should be held high or tied to VCC by the host. For proper operation in older

- hosts: while DMA operations are not active, the card shall ignore this signal, including a floating condition
- 6) Signal usage in True IDE Mode except when Ultra DMA mode protocol is active.
 - 7) Signal usage in True IDE Mode when Ultra DMA mode protocol DMA Write is active.
 - 8) Signal usage in True IDE Mode when Ultra DMA mode protocol DMA Read is active.
 - 9) Signal usage in PC Card I/O and Memory Mode when Ultra DMA mode protocol DMA Write is active.
 - 10) Signal usage in PC Card I/O and Memory Mode when Ultra DMA mode protocol DMA Read is active.
 - 11) Signal usage in PC Card I/O and Memory Mode when Ultra DMA protocol is active.
 - 12) Signal is a totem-pole output during Ultra DMA data bursts in True IDE mode.
 - 13) The mode is optional for CF+ Cards, but required for CompactFlash Storage Cards.

3.2 Electrical Description

The CompactFlash Card functions in three basic modes:

- 1) PC Card ATA using I/O Mode
- 2) PC Card ATA using Memory Mode
- 3) True IDE Mode, which is compatible with most disk drives.

ATP Industrial CompactFlash Card supports all three modes. The configuration of the CompactFlash Card is controlled using the standard PCMCIA configuration registers starting at address 200h in the Attribute Memory space of the storage card or for True IDE Mode, pin 9 being grounded.

Table 3-2: Signal Description

| SIGNAL NAME | DIR. | PIN | DESCRIPTION |
|---|------|---|---|
| A10 - A0 (PC Card Memory Mode) | I | 8,10,11,12, 14,15,16,17, 18,19,20 | These address lines along with the -REG signal are used to select the following: The I/O port address registers within the CompactFlash Card, the memory mapped port address registers within the CompactFlash Card, a byte in the card's information structure and its configuration control and status registers. |
| A10 - A0 (PC Card I/O Mode) | | | This signal is the same as the PC Card Memory Mode signal. |
| A2 - A0 (True IDE Mode) | | 18,19,20 | In True IDE Mode, only A[2:0] are used to select the one of eight registers in the Task File, the remaining address lines should be grounded by the host. |
| BVD1 (PC Card Memory Mode) | I/O | 46 | This signal is asserted high, as BVD1 is not supported. |
| -STSCHG (PC Card I/O Mode) Status Changed | | | This signal is asserted low to alert the host to changes in the READY and Write Protect states, while the I/O interface is configured. Its use is controlled by the Card Config and Status Register. |
| -PDIAG (True IDE Mode) | | | In the True IDE Mode, this input / output is the Pass Diagnostic signal in the Master / Slave handshake protocol. |
| BVD2 (PC Card Memory Mode) | I/O | 45 | This signal is asserted high, as BVD2 is not supported. |
| -SPKR (PC Card I/O Mode) | | | This line is the Binary Audio output from the card. If the Card does not support the Binary Audio function, this line should be held negated. |
| -CD1, -CD2 (PC Card Memory Mode) | O | 26,25 | These Card Detect pins are connected to ground on the CompactFlash Card. They are used by the host to determine that the CompactFlash Card is fully inserted into its socket. |

| SIGNAL NAME | DIR. | PIN | DESCRIPTION |
|--|------|--|--|
| -CE1, -CE2 (PC Card Memory Mode) Card Enable | I | 7,32 | <p>These input signals are used both to select the card and to indicate to the card whether a byte or a word operation is being performed. -CE2 always accesses the odd byte of the word. -CE1 accesses the even byte or the Odd byte of the word depending on A0 and -CE2. A multiplexing scheme based on A0, -CE1, -CE2 allows 8 bit hosts to access all data on D0-D7.</p> <p>This signal is the same as the PC Card Memory Mode signal.</p> <p>In the True IDE Mode, -CS0 is the chip select for the task file registers while -CS1 is used to select the Alternate Status Register and the Device Control Register.</p> <p>While -DMACK is asserted, -CS0 and -CS1 shall be held negated and the width of the transfers shall be 16 bits.</p> |
| -CE1, -CE2 (PC Card I/O Mode) Card Enable | | | |
| -CS0, -CS1 (True IDE Mode) | | | |
| -CSEL (PC Card Memory Mode) | I | 39 | <p>This signal is not used for this mode, but should be connected by the host to PC Card A25 or grounded by the host.</p> |
| -CSEL (PC Card I/O Mode) | | | <p>This signal is not used for this mode, but should be connected by the host to PC Card A25 or grounded by the host.</p> |
| -CSEL (True IDE Mode) | | | <p>This internally pulled up signal is used to configure this device as a Master or a Slave when configured in the True IDE Mode. When this pin is grounded, this device is configured as a Master. When the pin is open, this device is configured as a Slave.</p> |
| D15 - D00 (PC Card Memory Mode) | I/O | 31,30,29,28, 27,49,48,47, 6,5,4,3,2, 23, 22, 21 | <p>These lines carry the Data, Commands and Status information between the host and the controller. D00 is the LSB of the Even Byte of the Word. D08 is the LSB of the Odd Byte of the Word.</p> |
| D15 - D00 (PC Card I/O Mode) | | | <p>This signal is the same as the PC Card Memory Mode signal.</p> |
| D15 - D00 (True IDE Mode) | | | <p>In True IDE Mode, all Task File operations occur in byte mode on the low order bus D[7:0] while all data transfers are 16 bit using D[15:0].</p> |
| GND (PC Card Memory Mode) | -- | 1,50 | <p>Ground.</p> |
| GND (PC Card I/O Mode) | | | <p>This signal is the same for all modes.</p> |
| GND (True IDE Mode) | | | <p>This signal is the same for all modes.</p> |

| SIGNAL NAME | DIR. | PIN | DESCRIPTION |
|---|------|-----|--|
| <p>-INPACK (PC Card Memory Mode)</p> <p>-INPACK (PC Card I/O Mode) Input Acknowledge</p> <p>DMARQ (True IDE Mode)</p> | O | 43 | <p>This signal is not used in this mode.</p> <p>The Input Acknowledge signal is asserted by the CompactFlash Storage Card when the card is selected and responding to an I/O read cycle at the address that is on the address bus. This signal is used by the host to control the enable of any input data buffers between the CompactFlash Storage Card and the CPU.</p> <p>Hosts that support a single socket per interface logic, such as for Advanced Timing Modes and Ultra DMA operation may ignore the -INPACK signal from the device and manage their input buffers based solely on Card Enable signals.</p> <p>This signal is a DMA Request that is used for DMA data transfers between host and device. It shall be asserted by the device when it is ready to transfer data to or from the host. For Multiword DMA transfers, the direction of data transfer is controlled by -IORD and -IOWR. This signal is used in a handshake manner with (-)DMACK,</p> <p>In PCMCIA I/O Mode, the -DMARQ shall be ignored by the host while the host is performing an I/O Read cycle to the device. The host shall not initiate an I/O Read cycle while -DMARQ is asserted by the device.</p> <p>In True IDE Mode, DMARQ shall not be driven when the device is not selected in the Drive-Head register.</p> <p>While a DMA operation is in progress, -CS0 (-CE1) and -CS1 (-CE2) shall be held negated and the width of the transfers shall be 16 bits.</p> <p>If there is no hardware support for True IDE DMA mode in the host, this output signal is not used and should not be connected at the host. In this case, the BIOS must report that DMA mode is not supported by the host so that device drivers will not attempt DMA mode operation.</p> <p>A host that does not support DMA mode and implements both PC Card and True IDE modes of operation need not alter the PC Card mode connections while in True IDE mode as long as this does not prevent proper operation in any mode.</p> <p>is not selected in the Drive-Head register.</p> <p>While a DMA operation is in progress, -CS0 (-CE1) and -CS1 (-CE2) shall be held negated and the width of the transfers shall be 16 bits.</p> |

| SIGNAL NAME | DIR. | PIN | DESCRIPTION |
|--|------|-----|---|
| <p>-IORD (PC Card Memory Mode except Ultra DMA Protocol Active)</p> <p>-IORD (PC Card I/O Mode except Ultra DMA Protocol Active)</p> <p>-IORD (True IDE Mode – Except Ultra DMA Protocol Active)</p> <p>-HDMARDY (All Modes - Ultra DMA Protocol DMA Read)</p> <p>HSTROBE (All Modes - Ultra DMA Protocol DMA Write)</p> | I | 34 | <p>This signal is not used in this mode.</p> <p>This is an I/O Read strobe generated by the host. This signal gates I/O data onto the bus from the CompactFlash Storage Card when the card is configured to use the I/O interface.</p> <p>In True IDE Mode, while Ultra DMA mode is not active, this signal has the same function as in PC Card I/O Mode.</p> <p>In all modes when Ultra DMA mode DMA Read is active, this signal is asserted by the host to indicate that the host is ready to receive Ultra DMA data-in bursts. The host may negate – HDMARDY to pause an Ultra DMA transfer.</p> <p>In all modes when Ultra DMA mode DMA Write is active, this signal is the data out strobe generated by the host. Both the rising and falling edge of HSTROBE cause data to be latched by the device. The host may stop generating HSTROBE edges to pause an Ultra DMA data-out burst.</p> |
| <p>-IOWR (PC Card Memory Mode – Except Ultra DMA Protocol Active)</p> <p>-IOWR (PC Card I/O Mode – Except Ultra DMA Protocol Active)</p> <p>-IOWR (True IDE Mode – Except Ultra DMA Protocol Active)</p> <p>STOP (All Modes – Ultra DMA Protocol Active)</p> | I | 35 | <p>This signal is not used in this mode.</p> <p>The I/O Write strobe pulse is used to clock I/O data on the Card Data bus into the CompactFlash Storage Card controller registers when the CompactFlash Storage Card is configured to use the I/O interface. The clocking shall occur on the negative to positive edge of the signal (trailing edge).</p> <p>In True IDE Mode, while Ultra DMA mode protocol is not active, this signal has the same function as in PC Card I/O Mode. When Ultra DMA mode protocol is supported, this signal must be negated before entering Ultra DMA mode protocol.</p> <p>In All Modes, while Ultra DMA mode protocol is active, the assertion of this signal causes the termination of the Ultra DMA data burst.</p> |

| SIGNAL NAME | DIR. | PIN | DESCRIPTION |
|---|------|-----|---|
| -OE (PC Card Memory Mode) -OE (PC Card I/O Mode) -ATA SEL (True IDE Mode) | I | 9 | <p>This is an Output Enable strobe generated by the host interface. It is used to read data from the CompactFlash Card in Memory Mode and to read the CIS and configuration registers.</p> <p>In PC Card I/O Mode, this signal is used to read the CIS and configuration registers.</p> <p>To enable True IDE Mode this input should be grounded by the host.</p> |
| READY (PC Card Memory Mode) -IREQ (PC Card I/O Mode) INTRQ (True IDE Mode) | O | 37 | <p>In Memory Mode, this signal is set high when the CompactFlash Card is ready to accept a new data transfer operation and is held low when the card is busy.</p> <p>At power up and at Reset, the READY signal is held low (busy) until the CompactFlash Card has completed its power up or reset function. No access of any type should be made to the CompactFlash Card during this time.</p> <p>Note, however, that when a card is powered up and used with RESET continuously disconnected or asserted, the Reset function of the RESET pin is disabled. Consequently, the continuous assertion of RESET from the application of power shall not cause the READY signal to remain continuously in the busy state.</p> <p>I/O Operation – After the CompactFlash Card has been configured for I/O operation, this signal is used as -Interrupt Request. This line is strobed low to generate a pulse mode interrupt or held low for a level mode interrupt.</p> <p>In True IDE Mode signal is the active high Interrupt Request to the host.</p> |
| -REG (PC Card Memory Mode – Except Ultra DMA Protocol Active) Attribute Memory Select -REG (PC Card I/O Mode – Except Ultra DMA Protocol Active) -DMACK (PC Card Memory Mode when Ultra DMA Protocol Active) DMACK (PC Card I/O Mode when Ultra DMA Protocol Active) -DMACK (True IDE Mode) | I | 44 | <p>This signal is used during Memory Cycles to distinguish between Common Memory and Register (Attribute) Memory accesses. High for Common Memory, Low for Attribute Memory.</p> <p>In PC Card Memory Mode, when Ultra DMA Protocol is supported by the host and the host has enabled Ultra DMA protocol on the card the, host shall keep the -REG signal negated during the execution of any DMA Command by the Device</p> <p>The signal shall also be active (low) during I/O Cycles when the I/O address is on the Bus.</p> <p>In PC Card I/O Mode, when Ultra DMA Protocol is supported by the host and the host has enabled Ultra DMA protocol on the card the, host shall keep the -REG signal asserted during the execution of any DMA Command by the device.</p> <p>This is a DMA Acknowledge signal that is asserted by the host in response to (-)DMARQ to initiate DMA transfers.</p> <p>In True IDE Mode, while DMA operations are not active, the card shall ignore the (-)DMACK signal, including a floating condition. If DMA operation is not supported by a True IDE Mode only host, this signal should be driven high or connected to VCC by the host.</p> <p>A host that does not support DMA mode and implements both PC Card and True-IDE modes of operation need not alter the PC Card mode connections while in True-IDE mode as long as this does not prevent proper operation all modes.</p> |

| SIGNAL NAME | DIR. | PIN | DESCRIPTION |
|--|------|----------|---|
| RESET (PC Card Memory Mode) RESET (PC Card I/O Mode) -RESET (True IDE Mode) | I | 41 | <p>The CompactFlash Card is Reset when the RESET pin is high with the following important exception:</p> <p>The host may leave the RESET pin open or keep it continually high from the application of power without causing a continuous Reset of the card. Under either of these conditions, the card shall emerge from power-up having completed an initial Reset.</p> <p>The CompactFlash Card is also Reset when the Soft Reset bit in the Card Configuration Option Register is set.</p> <p>This signal is the same as the PC Card Memory Mode signal.</p> <p>In the True IDE Mode, this input pin is the active low hardware reset from the host.</p> |
| VCC (PC Card Memory Mode) VCC (PC Card I/O Mode) VCC (True IDE Mode) | -- | 13,38 | <p>+5 V, +3.3 V power.</p> <p>This signal is the same for all modes.</p> <p>This signal is the same for all modes.</p> |
| -VS1 -VS2 (PC Card Memory Mode) -VS1 -VS2 (PC Card I/O Mode) -VS1 -VS2 (True IDE Mode) | O | 33 40 | <p>Voltage Sense Signals. -VS1 is grounded on the Card and sensed by the Host so that the CompactFlash Card CIS can be read at 3.3 volts and -VS2 is reserved by PCMCIA for a secondary voltage and is not connected on the Card.</p> <p>This signal is the same for all modes.</p> <p>This signal is the same for all modes.</p> |

| SIGNAL NAME | DIR. | PIN | DESCRIPTION |
|--|------|-----|--|
| <p>-WAIT (PC Card Memory Mode – Except Ultra DMA Protocol Active)</p> <p>-WAIT (PC Card I/O Mode – Except Ultra DMA Protocol Active)</p> <p>IORDY (True IDE Mode – Except Ultra DMA Protocol Active)</p> <p>-DDMARDY (All Modes – Ultra DMA Write Protocol Active)</p> <p>DSTROBE (All Modes – Ultra DMA Read Protocol Active)</p> | O | 42 | <p>The -WAIT signal is driven low by the CompactFlash Storage Card to signal the host to delay completion of a memory or I/O cycle that is in progress.</p> <p>This signal is the same as the PC Card Memory Mode signal.</p> <p>In True IDE Mode, except in Ultra DMA modes, this output signal may be used as IORDY.</p> <p>In all modes, when Ultra DMA mode DMA Write is active, this signal is asserted by the device during a data burst to indicate that the device is ready to receive Ultra DMA data out bursts. The device may negate -DDMARDY to pause an Ultra DMA transfer.</p> <p>In all modes, when Ultra DMA mode DMA Read is active, this signal is the data in strobe generated by the device. Both the rising and falling edge of DSTROBE cause data to be latched by the host. The device may stop generating DSTROBE edges to pause an Ultra DMA data in burst.</p> |
| <p>-WE (PC Card Memory Mode)</p> <p>-WE (PC Card I/O Mode)</p> <p>-WE (True IDE Mode)</p> | I | 36 | <p>This is a signal driven by the host and used for strobing memory write data to the registers of the CompactFlash Card when the card is configured in the memory interface mode. It is also used for writing the configuration registers.</p> <p>In PC Card I/O Mode, this signal is used for writing the configuration registers.</p> <p>In True IDE Mode, this input signal is not used and should be connected to VCC by the host.</p> |
| <p>WP (PC Card Memory Mode) Write Protect</p> <p>-IOIS16 (PC Card I/O Mode)</p> <p>-IOCS16 (True IDE Mode)</p> | O | 24 | <p>Memory Mode – The CompactFlash Card does not have a write protect switch. This signal is held low after the completion of the reset initialization sequence.</p> <p>I/O Operation – When the CompactFlash Card is configured for I/O Operation Pin 24 is used for the -I/O Selected is 16 Bit Port (-IOIS16) function. A Low signal indicates that a 16 bit or odd byte only operation can be performed at the addressed port.</p> <p>In True IDE Mode this output signal is asserted low when this device is expecting a word data transfer cycle.</p> |

3.3 Electrical Specification

The following tables define all D.C. Characteristics for the ATP Industrial Grade CompactFlash Card Series. Unless otherwise stated, conditions are:

$$V_{cc} = 5V \pm 10\%$$

$$V_{cc} = 3.3V \pm 10\%$$

Table 3-3: Absolute Maximum Conditions

| PARAMETER | SYMBOL | CONDITIONS |
|--|-----------------|---|
| Input Power | V _{cc} | -0.3V min. to 6.5V max. |
| Voltage on any pin except V _{cc} with respect to GND. | V | -0.5V min. to V _{cc} + 0.5V max. |

3.3.1 Input Leakage Current

Note: In Table 3-4 below, x refers to the characteristics. For example, I1U indicates a pull-up resistor with a type 1 input characteristic.

Table 3-4: Input Leakage Current

| TYPE | PARAMETER | SYMBOL | CONDITIONS | MIN | TYP | MAX | UNITS |
|-----------------|-----------------------|--------|--|-----|-----|------|-------|
| I _{xZ} | Input Leakage Current | IL | V _{ih} = V _{cc} / V _{il} = Gnd | -1 | | 1 | μA |
| I _{xU} | Pull-Up Resistor | RPU1 | V _{cc} = 5.0V | 50k | | 500k | Ohm |
| I _{xD} | Pull-Down Resistor | RPD1 | V _{cc} = 5.0V | 50k | | 500k | Ohm |

Note:

The minimum pull-up resistor leakage current meets the PCMCIA specification of 10k ohms but is intentionally higher in the CompactFlash Specification to reduce power use.

3.3.2 Input Characteristics

Table 3-5: Input Characteristics

| TYPE | PARAMETER | SYMBOL | MIN | TYP | MAX | MIN | TYP | MAX | UNITS |
|------|---------------------------------------|------------------------------------|-------------|------------|-----|------------------|------------|-----|-------|
| | | | VCC = 3.3 V | | | VCC = 5.0 V | | | |
| 1 | Input Voltage CMOS | V _{ih} V _{il} | 2.4 | | 0.6 | 4.0 ¹ | | 0.8 | Volts |
| 2 | Input Voltage CMOS | V _{ih} V _{il} | 1.5 | | 0.6 | 2.0 | | 0.8 | Volts |
| 3 | Input Voltage CMOS Schmitt Trigger | V _{th} V _{tl} | | 1.8 1.0 | | | 2.8 2.0 | | Volts |

Notes:

Per PCMCIA Electrical Specification Signal Interface note 1, the host provides a logic output high voltage for a CMOS load of .9 x VCC. For a 5 volt product, this translates to .9 x 4.5 = 4.05 volts minimum Voh.

In UDMA modes greater than 4, the following characteristics apply. Voltage output high and low values shall be met at the source connector to include the effect of series termination.

Table 3-6: Input Characteristics (UDMA Mode > 4)

| PARAMETER | SYMBOL | MIN | MAX | UNITS |
|---|---------------------|----------|----------|-------|
| DC supply voltage to receivers | V _{DD3} | 3.3 - 8% | 3.3 + 8% | Volts |
| Low to high input threshold | V ₊ | 1.5 | 2.0 | Volts |
| High to low input threshold | V ₋ | 1.0 | 1.5 | Volts |
| Difference between input thresholds: ((V ₊ current value) - (V ₋ current value)) | V _{HYS} | 320 | | mV |
| Average of thresholds: ((V ₊ current value) + (V ₋ current value))/2 | V _{THRAVG} | 1.3 | 1.7 | Volts |

Note:

In Table 3-7 below, x refers to the characteristics. For example, OT3 refers to Totem pole output with a type 3 output drive characteristic.

3.3.3 Output Drive Type

Table 3-7: Output Drive Type

| TYPE | OUTPUT TYPE | VALID CONDITIONS |
|------|-----------------------|-----------------------------------|
| OTx | Totem pole | I _{oh} & I _{ol} |
| OZx | Tri-State N-P Channel | I _{oh} & I _{ol} |
| OPx | P-Channel Only | I _{oh} Only |
| ONx | N-Channel Only | I _{ol} Only |

3.3.4 Output Drive Characteristics

Table 3-8: Output Drive Characteristics

| TYPE | PARAMETER | SYMBOL | CONDITIONS | MIN | TYP | MAX | UNITS |
|------|---------------------------|------------|---------------------------|-----------|-----|-----------|-------|
| 1 | Output Voltage | Voh Vol | Ioh = -4 mA Iol = 4 mA | Vcc -0.8V | | Gnd +0.4V | Volts |
| 2 | Output Voltage | Voh Vol | Ioh = -4 mA Iol = 4 mA | Vcc -0.8V | | Gnd +0.4V | Volts |
| 3 | Output Voltage | Voh Vol | Ioh = -4 mA Iol = 4 mA | Vcc -0.8V | | Gnd +0.4V | Volts |
| X | Tri-State Leakage Current | Ioz | Vol = Gnd Voh = Vcc | -10 | | 10 | μA |

In UDMA modes greater than 4, the characteristics specified in the following table apply. Voltage output high and low values shall be met at the source connector to include the effect of series termination.

Table 3-9: Output Drive (UDMA Mode > 4)

| PARAMETER | SYMBOL | MIN | MAX | UNITS |
|---|------------------|-------------------------|------------------------|-------|
| DC supply voltage to drivers | V _{DD3} | 3.3 - 8% | 3.3 + 8% | Volts |
| Voltage output high at -6 mA to +3 mA (at VoH2 the output shall be able to supply and sink current to VDD3) | V _{oH2} | V _{DD3} - 0.51 | V _{DD3} + 0.3 | Volts |
| Voltage output low at 6 mA | V _{oL2} | | 0.51 | Volts |

Notes:

- 1) IoLDASP shall be 12 mA minimum to meet legacy timing and signal integrity.
- 2) IoH value at 400 μA is insufficient in the case of DMARQ that is pulled low by a 5.6 kΩ resistor.
- 3) Voltage output high and low values shall be met at the source connector to include the effect of series termination.
- 4) A device shall have less than 64 μA of leakage current into a 6.2 kΩ pull-down resistor while the INTRQ signal is in the released state.

3.3.5 Attribute Memory Read Timing

Attribute Memory access time is defined as 300 ns. Detailed timing specs are shown in Table 3-10.

Table 3-10: Attribute Memory Read Timing

| SPEED VERSION | | | 300 NS | |
|--------------------------------|---------------|-------------|---------|---------|
| ITEM | SYMBOL | IEEE SYMBOL | MIN ns. | MAX ns. |
| Read Cycle Time | $t_{c(R)}$ | t_{AVAV} | 300 | |
| Address Access Time | $t_{a(A)}$ | t_{AVQV} | | 300 |
| Card Enable Access Time | $t_{a(CE)}$ | t_{ELQV} | | 300 |
| Output Enable Access Time | $t_{a(OE)}$ | t_{GLQV} | | 150 |
| Output Disable Time from CE | $t_{dis(CE)}$ | t_{EHQZ} | | 100 |
| Output Disable Time from OE | $t_{dis(OE)}$ | t_{GHQZ} | | 100 |
| Address Setup Time | $t_{su(A)}$ | t_{AVGL} | 30 | |
| Output Enable Time from CE | $t_{en(CE)}$ | t_{ELQNZ} | 5 | |
| Output Enable Time from OE | $t_{en(OE)}$ | t_{GLQNZ} | 5 | |
| Data Valid from Address Change | $t_{v(A)}$ | t_{AXQX} | 0 | |

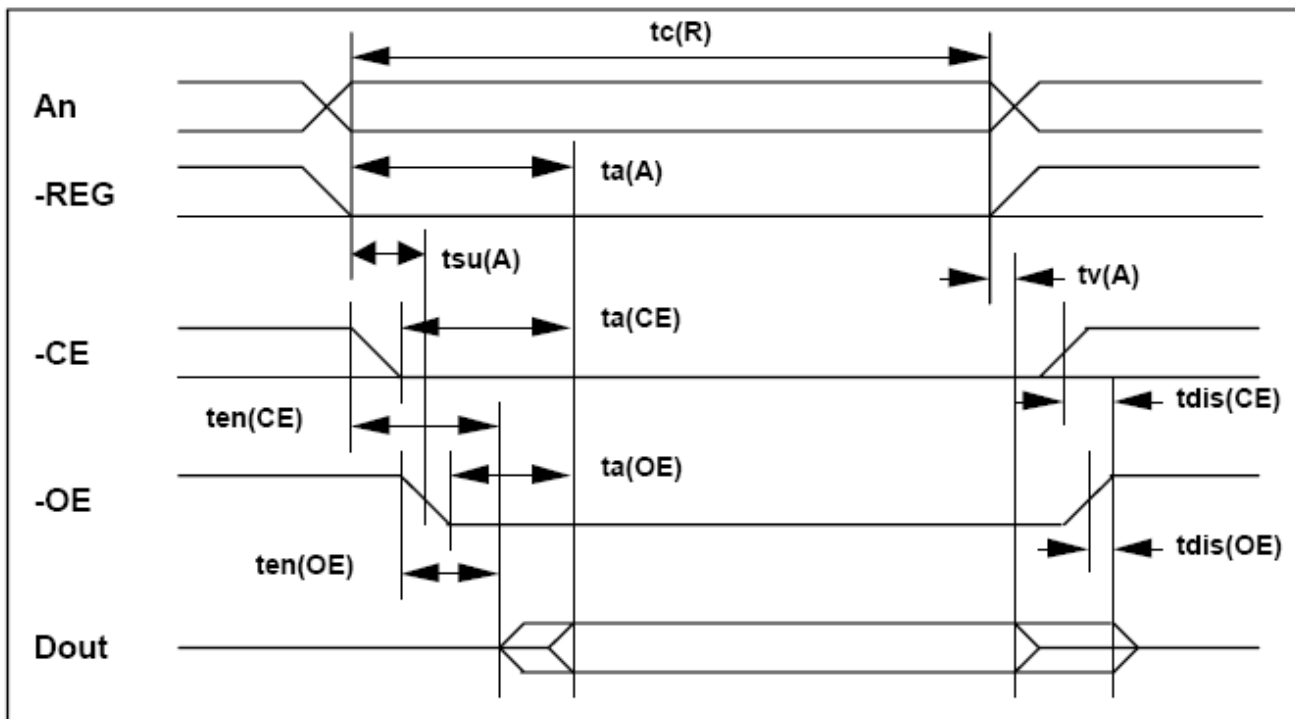

Figure 3-1: Attribute Memory Read Timing Diagram

3.3.6 Configuration Register (Attribute Memory) Write Timing Specification

Table 3-11: Configuration Register (Attribute Memory) Write Timing

| SPEED VERSION | | | 250 ns | |
|------------------------|-----------------|-------------|--------|--------|
| ITEM | SYMBOL | IEEE SYMBOL | MIN ns | MAX ns |
| Write Cycle Time | $T_c(W)$ | t_{AVAV} | 250 | |
| Write Pulse Width | $T_w(WE)$ | t_{WLWH} | 150 | |
| Address Setup Time | $t_{su}(A)$ | t_{AVWL} | 30 | |
| Write Recovery Time | $t_{rec}(WE)$ | t_{WMAX} | 30 | |
| Data Setup Time for WE | $t_{su}(D-WEH)$ | t_{DVWH} | 80 | |
| Data Hold Time | $T_h(D)$ | t_{WMDX} | 30 | |

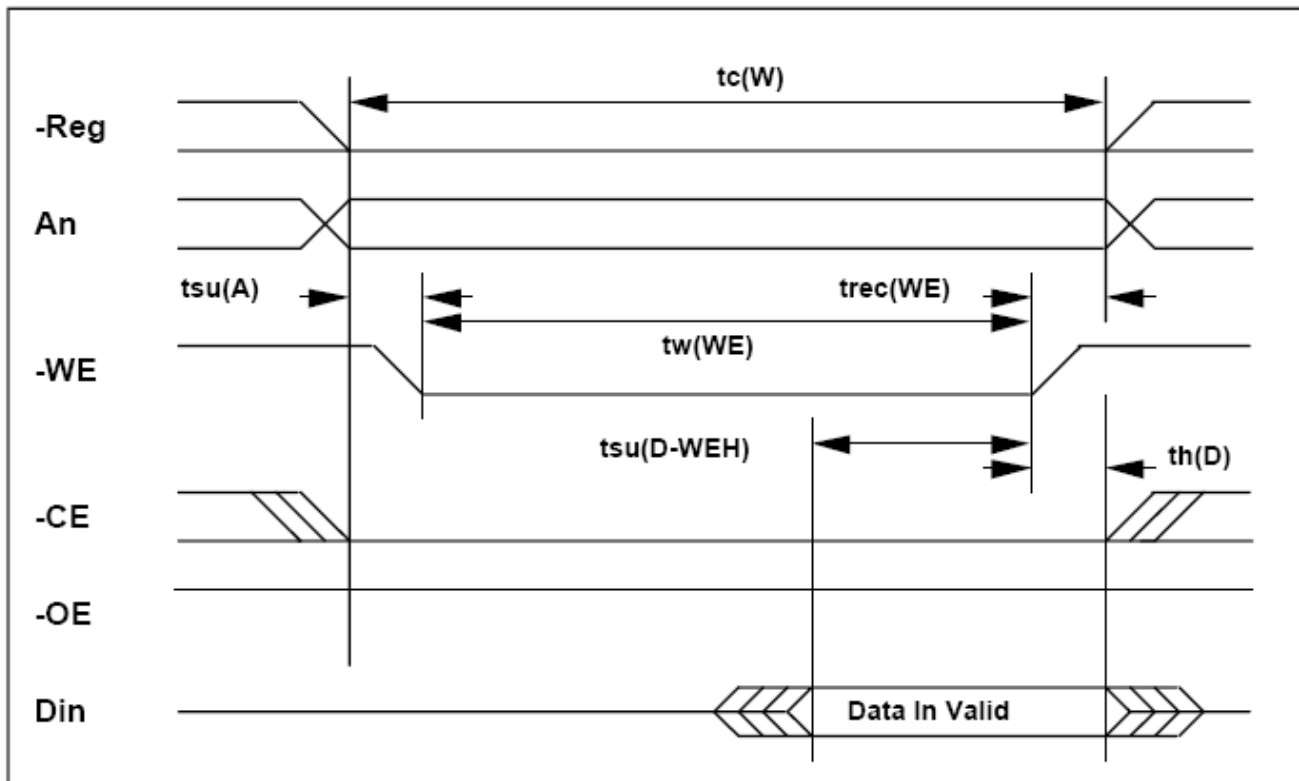

Figure 3-2: Configuration Register (Attribute Memory) Write Timing Diagram

3.3.7 Common Memory Read Timing Specification

Table 3-12: Common Memory Read Timing

| CYCLE TIME MODE: | | | 250 ns | | 120 ns | | 100 ns | | 80 ns | |
|------------------------------|-----------|-------------|---------|---------|---------|---------|---------|---------|---------|-----------------|
| ITEM | SYMBOL | IEEE SYMBOL | MIN ns. | MAX ns. | MIN ns. | MAX ns. | MIN ns. | MAX ns. | MIN ns. | MAX ns. |
| Output Enable Access Time | ta(OE) | tGLQV | | 125 | | 60 | | 50 | | 45 |
| Output Disable Time from OE | tdis(OE) | tGHQZ | | 100 | | 60 | | 50 | | 45 |
| Address Setup Time | tsu(A) | tAVGL | 30 | | 15 | | 10 | | 10 | |
| Address Hold Time | th(A) | tGHAX | 20 | | 15 | | 15 | | 10 | |
| CE Setup before OE | tsu(CE) | tELGL | 0 | | 0 | | 0 | | 0 | |
| CE Hold following OE | th(CE) | tGHEH | 20 | | 15 | | 15 | | 10 | |
| Wait Delay Falling from OE | tv(WT-OE) | tGLWTV | | 35 | | 35 | | 35 | | na ¹ |
| Data Setup for Wait Release | tv(WT) | tQVWTH | | 0 | | 0 | | 0 | | na ¹ |
| Wait Width Time ² | tw(WT) | tWTLWTH | | 350 | | 350 | | 350 | | na ¹ |

Notes:

1) -WAIT is not supported in this mode.

2) The maximum load on -WAIT is 1 LSTTL with 50 pF (40pF below 120nsec Cycle Time) total load.

All times are in nanoseconds. Dout signifies data provided by the CompactFlash Card to the system. The -WAIT signal may be ignored if the -OE cycle to cycle time is greater than the Wait Width time. The Max Wait Width time can be determined from the Card Information Structure. The Wait Width time meets the PCMCIA specification of 12μs but is intentionally less in this specification.

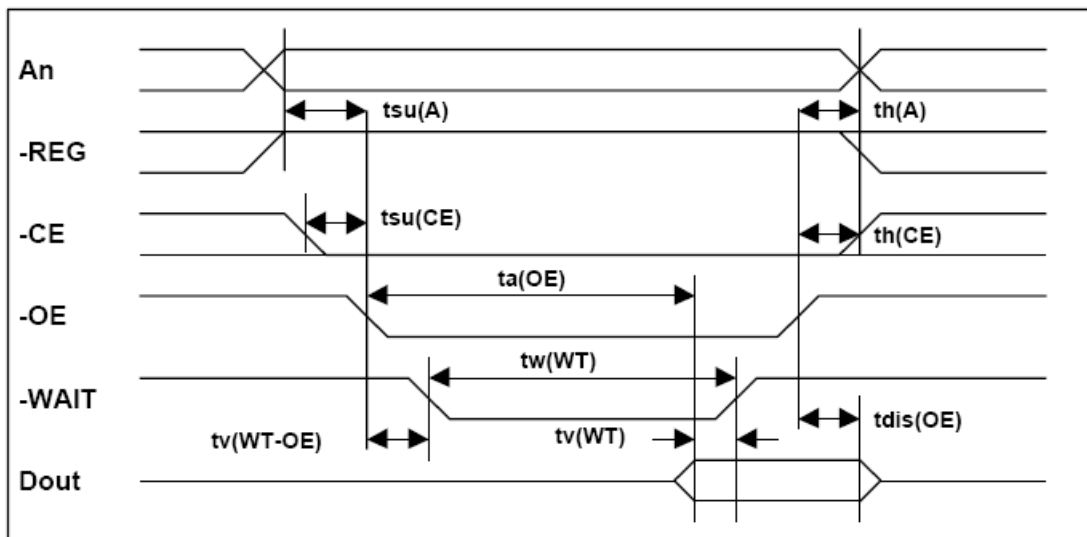

Figure 3-3: Common Memory Read Timing Diagram

3.3.8 Common Memory Write Timing Specification

Table 3-13: Common Memory Write Timing

| CYCLE TIME MODE: | | | 250 ns | | 120 ns | | 100 ns | | 80 ns | |
|------------------------------|-------------|-------------|---------|---------|---------|---------|---------|---------|-----------------|-----------------|
| ITEM | SYMBOL | IEEE SYMBOL | MIN ns. | MAX ns. | MIN ns. | MAX ns. | MIN ns. | MAX ns. | MIN ns. | MAX ns. |
| Data Setup before WE | tsu (D-WEH) | tDVWH | 80 | | 50 | | 40 | | 30 | |
| Data Hold following WE | th(D) | tWMDX | 30 | | 15 | | 10 | | 10 | |
| WE Pulse Width | tw(WE) | tWLWH | 150 | | 70 | | 60 | | 55 | |
| Address Setup Time | tsu(A) | tAVWL | 30 | | 15 | | 10 | | 10 | |
| CE Setup before WE | tsu(CE) | tELWL | 0 | | 0 | | 0 | | 0 | |
| Write Recovery Time | trec(WE) | tWMAX | 30 | | 15 | | 15 | | 15 | |
| Address Hold Time | th(A) | tGHAX | 20 | | 15 | | 15 | | 15 | |
| CE Hold following WE | th(CE) | tGHEH | 20 | | 15 | | 15 | | 10 | |
| CYCLE TIME MODE: | | | 250 ns | | 120 ns | | 100 ns | | 80 ns | |
| ITEM | SYMBOL | IEEE SYMBOL | MIN ns. | MAX ns. | MIN ns. | MAX ns. | MIN ns. | MAX ns. | MIN ns. | MAX ns. |
| Wait Delay Falling from WE | tv (WT-WE) | tWLWTV | | 35 | | 35 | | 35 | | na ¹ |
| WE High from Wait Release | tv(WT) | tWTHWH | 0 | | 0 | | 0 | | na ¹ | |
| Wait Width Time ² | tw (WT) | tWTLWTH | | 350 | | 350 | | 350 | | na ² |

Notes:

1) -WAIT is not supported in this mode.

2) The maximum load on -WAIT is 1 LSTTL with 50 pF (40pF below 120nsec Cycle Time) total load.

All times are in nanoseconds. Din signifies data provided by the system to the CompactFlash Card. The -WAIT signal may be ignored if the -WE cycle to cycle time is greater than the Wait Width time. The Max Wait Width time can be determined from the Card Information Structure. The Wait Width time meets the PCMCIA specification of 12μs but is intentionally less in this specification.

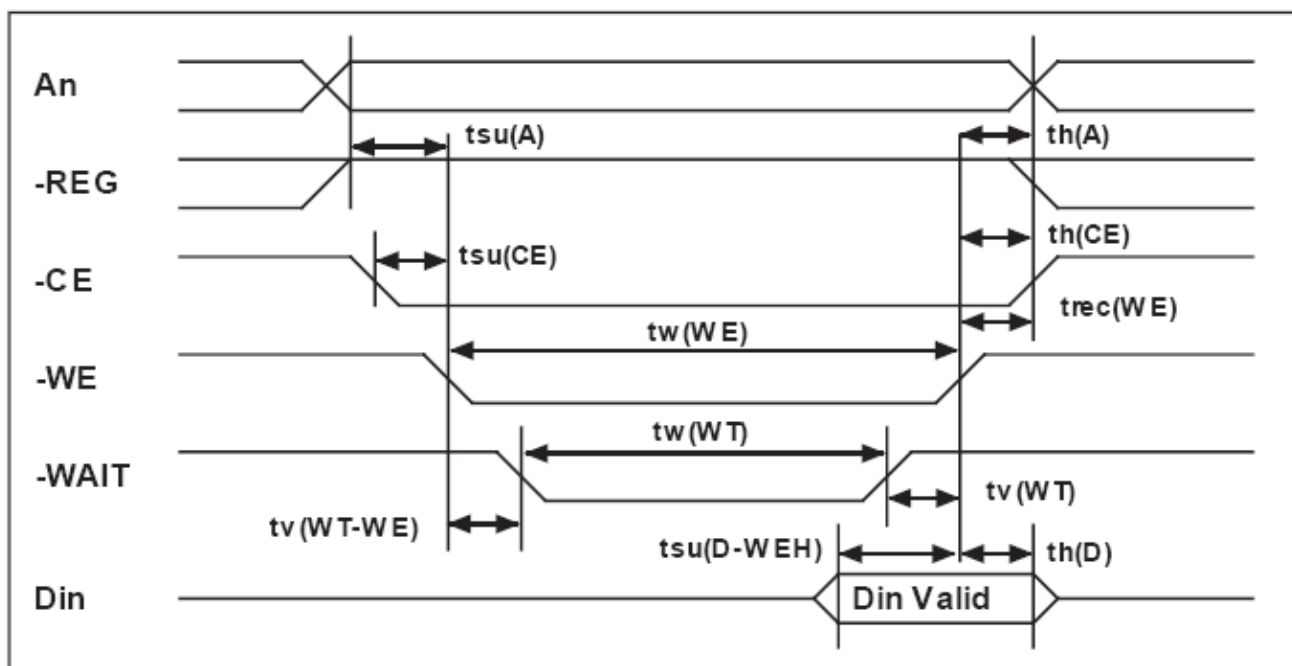

Figure 3-4: Common Memory Write Timing

3.3.9 I/O Input (Read) Timing Specification

Table 3-14: I/O Read Timing

| CYCLE TIME MODE: | | | 250 ns | | 120 ns | | 100 ns | | 80 ns | |
|-----------------------------|-------------|--------------------|---------|---------|---------|---------|---------|---------|---------|---------|
| ITEM | SYMBOL | IEEE SYMBOL | MIN ns. | MAX ns. | MIN ns. | MAX ns. | MIN ns. | MAX ns. | MIN ns. | MAX ns. |
| Data Delay after IORD | td(IORD) | t _{GLQV} | | 100 | | 50 | | 50 | | 45 |
| Data Hold following IORD | th(IORD) | t _{GHQX} | 0 | | 5 | | 5 | | 5 | |
| IORD Width Time | tw(IORD) | t _{GLIGH} | 165 | | 70 | | 65 | | 55 | |
| Address Setup before IORD | tsuA(IORD) | t _{AVIGL} | 70 | | 25 | | 25 | | 15 | |
| Address Hold following IORD | thA(IORD) | t _{GHAX} | 20 | | 10 | | 10 | | 10 | |
| CE Setup before IORD | tsuCE(IORD) | t _{ELIGL} | 5 | | 5 | | 5 | | 5 | |
| CE Hold following IORD | thCE(IORD) | t _{LGHEH} | 20 | | 10 | | 10 | | 10 | |

| | | | | | | | | | | |
|--|------------------|---------|---|-----|---|-----------------|---|-----------------|---|-----------------|
| REG Setup before IORD | tsuREG (IORD) | tRGLIGL | 5 | | 5 | | 5 | | 5 | |
| REG Hold following IORD | thREG (IORD) | tIGHRGH | 0 | | 0 | | 0 | | 0 | |
| INPACK Delay Falling from IORD ³ | tdfINPACK (IORD) | tIGLIAL | 0 | 45 | 0 | na ¹ | 0 | na ¹ | 0 | na ¹ |
| INPACK Delay Rising from IORD ³ | tdrINPACK (IORD) | tIGHIAH | | 45 | | na ¹ | | na ¹ | | na ¹ |
| IOIS16 Delay Falling from Address ³ | tdfIOIS16 (ADR) | tAVISL | | 35 | | na ¹ | | na ¹ | | na ¹ |
| IOIS16 Delay Rising from Address ³ | tdrIOIS16 (ADR) | tAVISH | | 35 | | na ¹ | | na ¹ | | na ¹ |
| Wait Delay Falling from IORD ³ | tdWT(IORD) | tIGLWTL | | 35 | | 35 | | 35 | | na ² |
| Data Delay from Wait Rising ³ | td(WT) | tWTHQV | | 0 | | 0 | | 0 | | na ² |
| Wait Width Time ³ | tw(WT) | tWTLWTH | | 350 | | 350 | | 350 | | na ² |

Notes:

- 1) -IOIS16 and -INPACK are not supported in this mode.
- 2) -WAIT is not supported in this mode.
- 3) Maximum load on -WAIT, -INPACK and -IOIS16 is 1 LSTTL with 50 pF (40pF below 120nsec Cycle Time) total load. All times are in nanoseconds. Minimum time from -WAIT high to -IORD high is 0 nsec, but minimum -IORD width shall still be met. Dout signifies data provided by the CompactFlash Card to the system. Wait Width time meets PCMCIA specification of 12µs but is intentionally less in this spec.

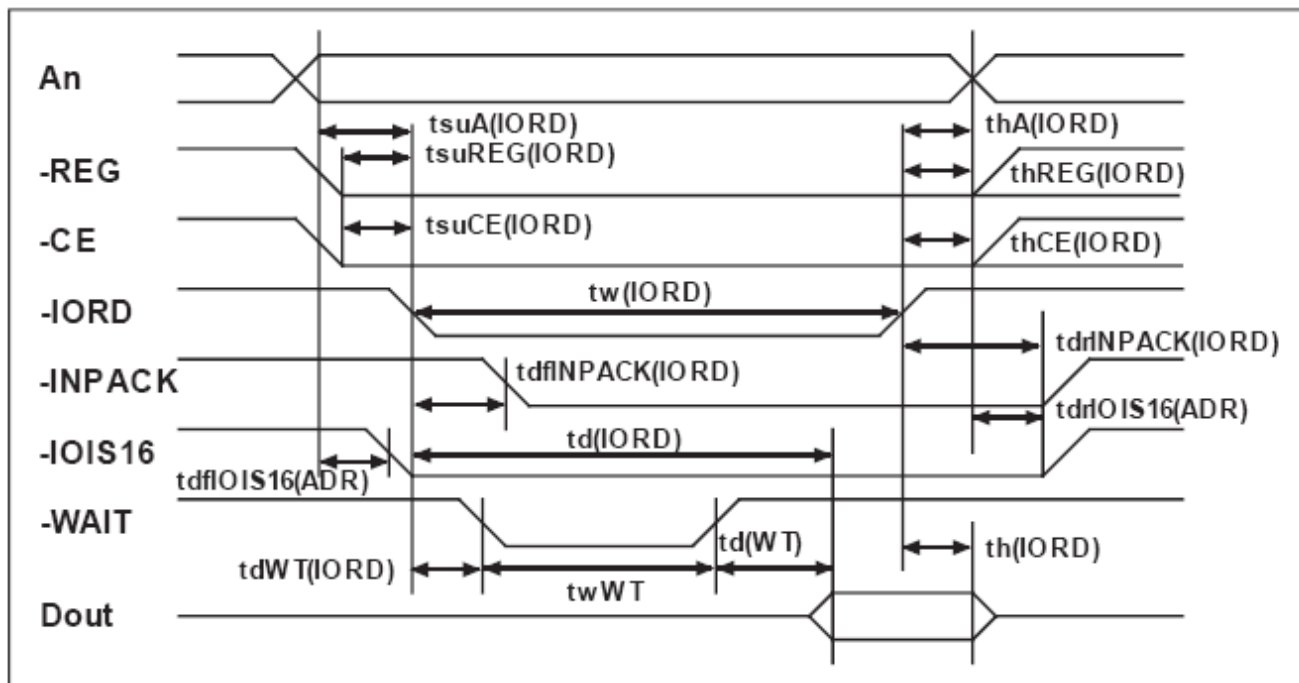

Figure 3-5: I/O Read Timing Diagram

3.3.10 I/O Output (Write) Timing Specification

Table 3-15: I/O Write Timing

| CYCLE TIME MODE: | | | 255 ns | | 120 ns | | 100 ns | | 80 ns | |
|------------------------------------|-----------------|-------------|---------|---------|---------|---------|---------|---------|---------|---------|
| ITEM | SYMBOL | IEEE SYMBOL | MIN ns. | MAX ns. | MIN ns. | MAX ns. | MIN ns. | MAX ns. | MIN ns. | MAX ns. |
| Data Setup before IOWR | tsu(IOWR) | tDVIWH | 60 | | 20 | | 20 | | 15 | |
| Data Hold following IOWR | th(IOWR) | tLWHDX | 30 | | 10 | | 5 | | 5 | |
| IOWR Width Time | tw(IOWR) | tLWLIWH | 165 | | 70 | | 65 | | 55 | |
| Address Setup before IOWR | tsuA(IOWR) | tAVIWL | 70 | | 25 | | 25 | | 15 | |
| Address Hold following IOWR | thA(IOWR) | tLWHAX | 20 | | 20 | | 10 | | 10 | |
| CE Setup before IOWR | tsuCE (IOWR) | tELIWL | 5 | | 5 | | 5 | | 5 | |
| CE Hold following IOWR | thCE (IOWR) | tLWHEH | 20 | | 20 | | 10 | | 10 | |
| REG Setup before IOWR | tsuREG (IOWR) | tRGLIWL | 5 | | 5 | | 5 | | 5 | |
| REG Hold following IOWR | thREG (IOWR) | tLWHRGH | 0 | | 0 | | 0 | | 0 | |
| IOIS16 Delay Falling from Address3 | tdfIOIS16 (ADR) | tAVISL | | 35 | | na1 | | na1 | | na1 |
| IOIS16 Delay Rising from Address3 | tdrIOIS16 (ADR) | tAVISH | | 35 | | na1 | | na1 | | na1 |
| Wait Delay Falling from IOWR3 | tdWT(IOWR) | tLWLWTL | | 35 | | 35 | | 35 | | na2 |
| IOWR high from Wait high3 | tdrIOWR (WT) | tWTJIWH | 0 | | 0 | | 0 | | na2 | |
| Wait Width Time3 | tw(WT) | tWTLWTH | | 350 | | 350 | | 350 | | na2 |

Notes:

- 1) -IOIS16 and -INPACK are not supported in this mode.
- 2) -WAIT is not supported in this mode.
- 3) The maximum load on -WAIT, -INPACK, and -IOIS16 is 1 LSTTL with 50 pF (40pF below 120nsec Cycle Time) total load. All times are in nanoseconds. Minimum time from -WAIT high to -IOWR high is 0 nsec, but minimum -IOWR width shall still be met. Din signifies data provided by the system to the CompactFlash Card. The Wait Width time meets the PCMCIA specification of 12 μ s but is intentionally less in this specification.

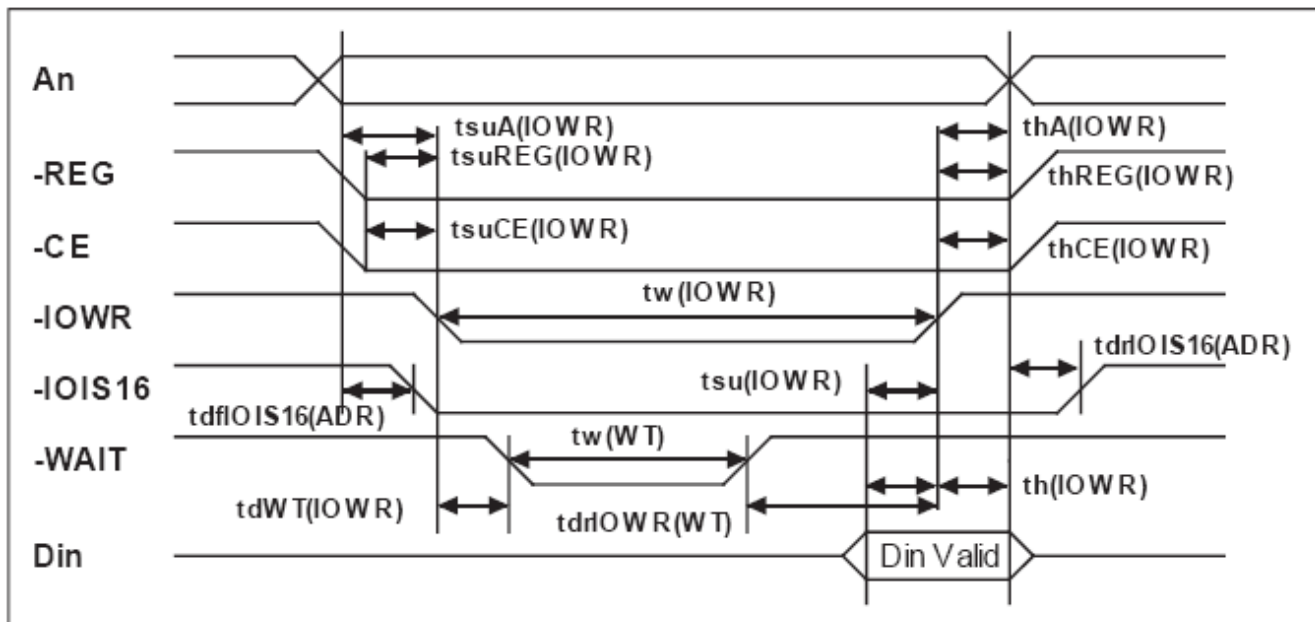

Figure 3-6: I/O Write Timing Diagram

3.3.11 True IDE PIO Mode Read/Write Timing Specification

The timing diagram for True IDE mode of operation in this section is drawn using the conventions in the ATA-4 specification, which are different than the conventions used in the PCMCIA specification and earlier versions of this specification. Signals are shown with their asserted state as high regardless of whether the signal is actually negative or positive true. Consequently, the -IORD, the -IOWR and the -IOCS16 signals are shown in the diagram inverted from their electrical states on the bus.

Table 3-16: True IDE PIO Mode Read/Write Timing

| | Item | Mode 0 | Mode 1 | Mode 2 | Mode 3 | Mode 4 | Mode 5 | Mode 6 | Note |
|-----|---|--------|--------|--------|--------|--------|-----------------|-----------------|------|
| t0 | Cycle time (min) | 600 | 383 | 240 | 180 | 120 | 100 | 80 | 1 |
| t1 | Address Valid to - IORD/-IOWR setup (min) | 70 | 50 | 30 | 30 | 25 | 15 | 10 | |
| t2 | -IORD/-IOWR (min) | 165 | 125 | 100 | 80 | 70 | 65 | 55 | 1 |
| t2 | -IORD/-IOWR (min) Register (8 bit) | 290 | 290 | 290 | 80 | 70 | 65 | 55 | 1 |
| t2i | -IORD/-IOWR recovery time (min) | - | - | - | 70 | 25 | 25 | 20 | 1 |
| t3 | -IOWR data setup (min) | 60 | 45 | 30 | 30 | 20 | 20 | 15 | |
| t4 | -IOWR data hold (min) | 30 | 20 | 15 | 10 | 10 | 5 | 5 | |
| t5 | -IORD data setup (min) | 50 | 35 | 20 | 20 | 20 | 15 | 10 | |
| t6 | -IORD data hold (min) | 5 | 5 | 5 | 5 | 5 | 5 | 5 | |
| t6Z | -IORD data tristate (max) | 30 | 30 | 30 | 30 | 30 | 20 | 20 | 2 |
| t7 | Address valid to - IOCS16 assertion (max) | 90 | 50 | 40 | n/a | n/a | n/a | n/a | 4 |
| t8 | Address valid to - IOCS16 released (max) | 60 | 45 | 30 | n/a | n/a | n/a | n/a | 4 |
| t9 | -IORD/-IOWR to address valid hold | 20 | 15 | 10 | 10 | 10 | 10 | 10 | |
| tRD | Read Data Valid to IORDY active (min), if IORDY initially low after tA | 0 | 0 | 0 | 0 | 0 | 0 | 0 | |
| tA | IORDY Setup time | 35 | 35 | 35 | 35 | 35 | na ⁵ | na ⁵ | 3 |
| tB | IORDY Pulse Width (max) | 1250 | 1250 | 1250 | 1250 | 1250 | na ⁵ | na ⁵ | |
| tC | IORDY assertion to release (max) | 5 | 5 | 5 | 5 | 5 | na ⁵ | na ⁵ | |

Notes:

All timings are in nanoseconds. The maximum load on -IOCS16 is 1 LSTTL with a 50 pF (40pF below 120nsec Cycle Time) total load. All times are in nanoseconds. Minimum time from -IORDY high to -IORD high is 0 nsec, but minimum -IORD width shall still be met.

1) t0 is the minimum total cycle time, t2 is the minimum command active time, and t2i is the minimum command recovery time or command inactive time. The actual cycle time equals the sum of the actual command active time and the actual command inactive time. The three timing requirements of t0, t2, and t2i shall be met. The minimum total cycle time requirement is greater than the sum of t2 and t2i. This means a host implementation can lengthen either or both t2 or t2i to ensure that t0 is equal to or greater than the value reported in the device's identify device data. A CompactFlash Storage Card implementation shall support any legal host implementation.

2) This parameter specifies the time from the negation edge of -IORD to the time that the data bus is no longer driven by the CompactFlash Storage Card (tri-state).

3) The delay from the activation of -IORD or -IOWR until the state of IORDY is first sampled. If IORDY is inactive then the host shall wait until IORDY is active before the PIO cycle can be completed. If the CompactFlash Storage Card is not driving IORDY negated at tA after the activation of -IORD or -IOWR, then t5 shall be met and tRD is not applicable. If the CompactFlash Storage Card is driving IORDY negated at the time tA after the activation of -IORD or -IOWR, then tRD shall be met and t5 is not applicable.

4) t7 and t8 apply only to modes 0, 1 and 2. For other modes, this signal is not valid.

5) IORDY is not supported in this mode.

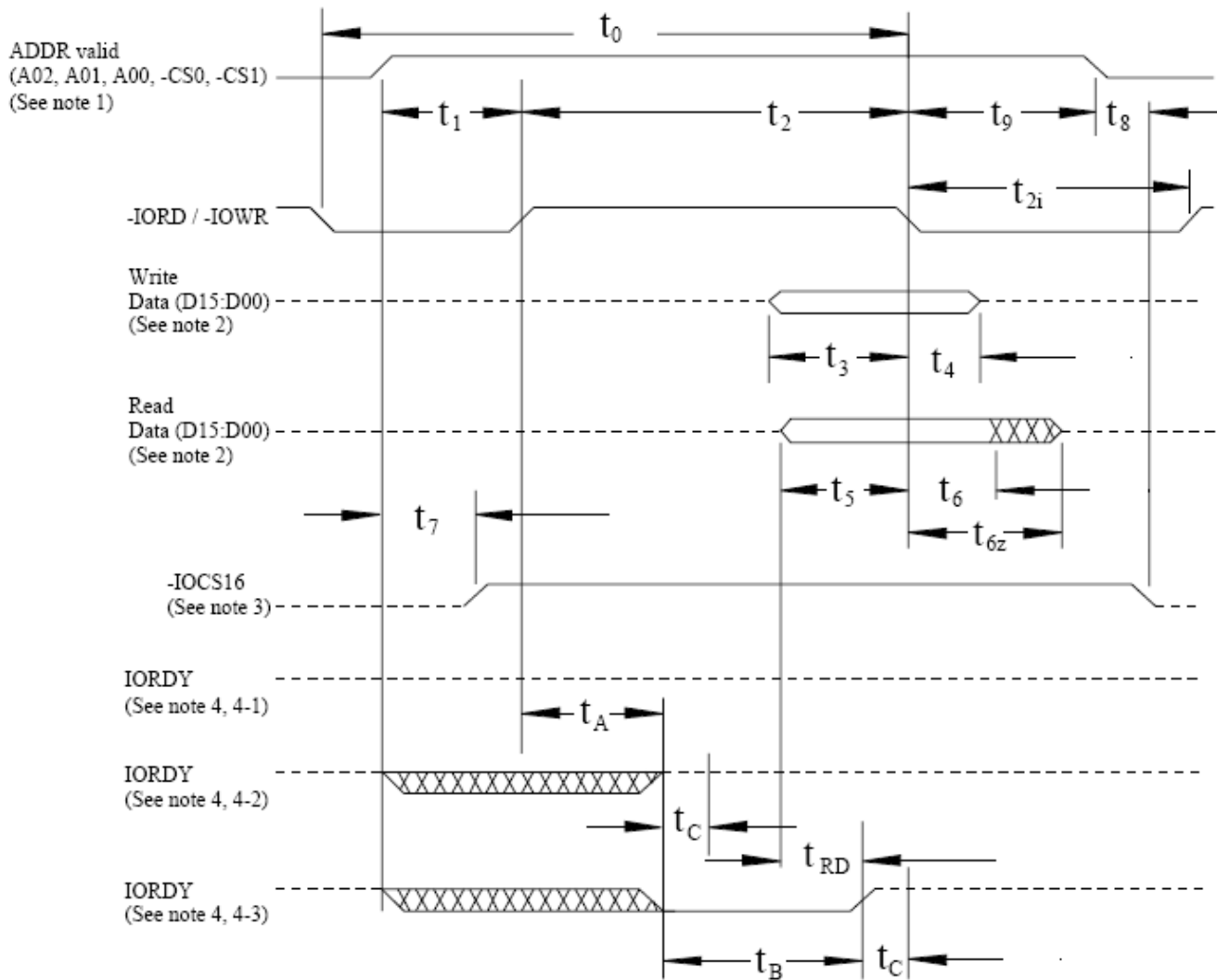

Figure 3-7: True IDE PIO Mode Timing Diagram

ALL WAVEFORMS IN THIS DIAGRAM ARE SHOWN WITH THE ASSERTED STATE HIGH.
NEGATIVE TRUE SIGNALS APPEAR INVERTED ON THE BUS RELATIVE TO THE DIAGRAM.

Notes:

- 1) Device address consists of -CS0, -CS1, and A[02::00]
- 2) Data consists of D[15::00] (16-bit) or D[07::00] (8 bit)
- 3) -IOCS16 is shown for PIO modes 0, 1 and 2. For other modes, this signal is ignored.
- 4) The negation of IORDY by the device is used to extend the PIO cycle. The determination of whether the cycle is to be extended is made by the host after t_A from the assertion of -IORD or -IOWR. The assertion and negation of IORDY is described in the following three cases:
 - 4-1) Device never negates IORDY: No wait is generated.
 - 4-2) Device starts to drive IORDY low before t_A , but causes IORDY to be asserted before t_A : No wait generated.
 - 4-3) Device drives IORDY low before t_A : wait generated. The cycle completes after IORDY is reasserted. For cycles where a wait is generated and -IORD is asserted, the device shall place read data on D15-D00 for t_{RD} before causing IORDY to be asserted.

3.3.12 True IDE Multiword DMA Mode Read/Write Timing Specification

The timing diagram for True IDE DMA mode of operation in this section is drawn using the conventions in the ATA-4 specification, which are different than the conventions used in the PCMCIA specification and earlier versions of this specification. Signals are shown with their asserted state as high regardless of whether the signal is actually negative or positive true. Consequently, the -IOR_D, the -IOW_R and the -IOCS₁₆ signals are shown in the diagram inverted from their electrical states on the bus.

Table 3-17: True IDE Multiword DMA Mode Read/Write Timing

| | Item | Mode 0 (ns) | Mode 1 (ns) | Mode 2 (ns) | Mode 3 (ns) | Mode 4 (ns) | Note |
|-----------------|--|----------------|----------------|----------------|----------------|----------------|------|
| t _O | Cycle time (min) | 480 | 150 | 120 | 100 | 80 | 1 |
| t _D | -IOR _D / -IOW _R asserted width (min) | 215 | 80 | 70 | 65 | 55 | 1 |
| t _E | -IOR _D data access (max) | 150 | 60 | 50 | 50 | 45 | |
| t _F | -IOR _D data hold (min) | 5 | 5 | 5 | 5 | 5 | |
| t _G | -IOR _D /-IOW _R data setup (min) | 100 | 30 | 20 | 15 | 10 | |
| t _H | -IOW _R data hold (min) | 20 | 15 | 10 | 5 | 5 | |
| t _I | DMACK to -IOR _D /-IOW _R setup (min) | 0 | 0 | 0 | 0 | 0 | |
| t _J | -IOR _D / -IOW _R to -DMACK hold (min) | 20 | 5 | 5 | 5 | 5 | |
| t _{KR} | -IOR _D negated width (min) | 50 | 50 | 25 | 25 | 20 | 1 |
| t _{KW} | -IOW _R negated width (min) | 215 | 50 | 25 | 25 | 20 | 1 |
| t _{LR} | -IOR _D to DMARQ delay (max) | 120 | 40 | 35 | 35 | 35 | |
| t _{LW} | -IOW _R to DMARQ delay (max) | 40 | 40 | 35 | 35 | 35 | |
| t _M | CS(1:0) valid to -IOR _D / -IOW _R | 50 | 30 | 25 | 10 | 5 | |
| t _N | CS(1:0) hold | 15 | 10 | 10 | 10 | 10 | |
| t _Z | -DMACK | 20 | 25 | 25 | 25 | 25 | |

Notes:

1) t_O is the minimum total cycle time and t_D is the minimum command active time, while t_{KR} and t_{KW} are the minimum command recovery time or command inactive time for input and output cycles respectively. The actual cycle time equals the sum of the actual command active time and the actual command inactive time. The three timing requirements of t_O, t_D, t_{KR}, and t_{KW} shall be met. The minimum total cycle time requirement is greater than the sum of t_D and t_{KR} or t_{KW} for input and output cycles respectively. This means a host implementation can lengthen either or both of t_D and either of t_{KR}, and t_{KW} as needed to ensure that t_O is equal to or greater than the value reported in the device's identify device data. A CompactFlash Storage Card implementation shall support any legal host implementation.

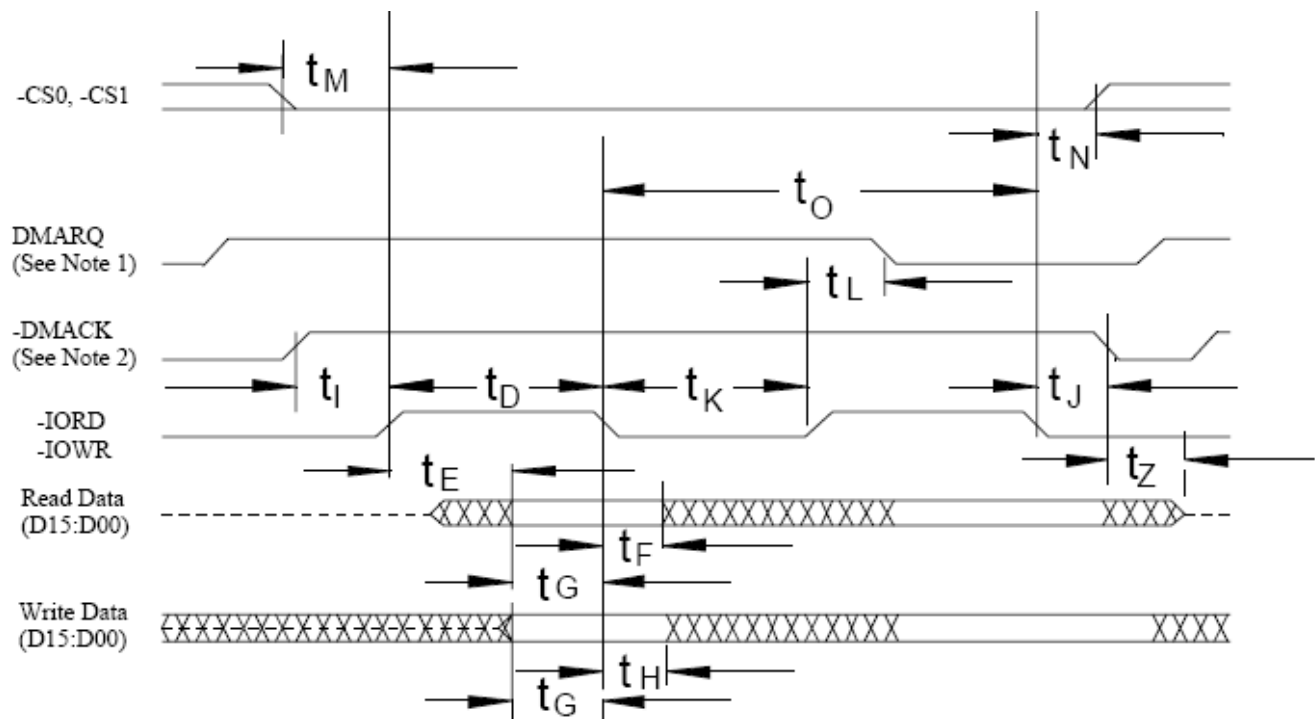

Notes:

- (1) If the Card cannot sustain continuous, minimum cycle time DMA transfers, it may negate DMARQ within the time specified from the start of a DMA transfer cycle to suspend the DMA transfers in progress and reassert the signal at a later time to continue the DMA operation.
- (2) This signal may be negated by the host to suspend the DMA transfer in progress.

Figure 3-8: True IDE Multiword DMA Mode Read/Write Timing Diagram

3.3.13 Ultra DMA Mode Read/Write Timing Specification

Ultra DMA Overview

Ultra DMA is an optional data transfer protocol used with the READ DMA, and WRITE DMA, commands. When this protocol is enabled, the Ultra DMA protocol shall be used instead of the Multiword DMA protocol when these commands are issued by the host. This protocol applies to the Ultra DMA data burst only. When this protocol is used there are no changes to other elements of the ATA protocol (e.g., Command Block Register access).

Ultra DMA operations can take place in any of the three basic interface modes: PC Card Memory mode, PC Card I/O mode, and True IDE (the original mode to support UDMA). The usage of signals in each of the modes is shown in Table 3-18:Ultra DMA Signal Usage In Each Interface Mode

Table 3-18:Ultra DMA Signal Usage In Each Interface Mode

| UDMA Signal | Type | Pin # (Non UDMA MEM MODE) | PC CARD MEM MODE UDMA | PC CARD IO MODE UDMA | TRUE IDE MODE UDMA |
|--------------------------|--------|---------------------------|--|---|---|
| DMARQ | Output | 43 (-INPACK) | -DMARQ | -DMARQ | DMARQ |
| DMACK | Input | 44 (-REG) | -DMACK | DMACK | -DMACK |
| STOP | Input | 35 (-IOWR) | STOP 1 | STOP 1 | STOP 1 |
| HDMARDY(R) HSTROBE(W) | Input | 34 (-IORD) | -HDMARDY(R) 1, 2HSTROBE(W) 1, 3, 4 | -HDMARDY(R) 1, 2 HSTROBE(W) 1, 3, 4 | -HDMARDY(R) 1, 2 HSTROBE(W) 1, 3, 4 |
| DDMARDY(W) DSTROBE(R) | Output | 42 (-WAIT) | -DDMARDY(W) 1, 3DSTROBE(R) 1. 2. 4 | -DDMARDY(W) 1, 3 DSTROBE(R) 1. 2. 4 | -DDMARDY(W) 1, 3 DSTROBE(R) 1. 2. 4 |
| DATA | Bidir | ... (D[15:00]) | D[15:00] | D[15:00] | D[15:00] |
| ADDRESS | Input | ... (A[10:00]) | A[10:00] | A[10:00] | A[02:00] 5 |
| CSEL | Input | 39 (-CSEL) | -CSEL | -CSEL | -CSEL |
| INTRQ | Output | 37 (READY) | READY | -INTRQ | INTRQ |
| Card Select | Input | 7 (-CE1) 31 (-CE2) | -CE1 -CE2 | -CE1 -CE2 | -CS0 -CS1 |

Notes:

- 1) The UDMA interpretation of this signal is valid only during an Ultra DMA data burst.
- 2) The UDMA interpretation of this signal is valid only during and Ultra DMA data burst during a DMA Read command.
- 3) The UDMA interpretation of this signal is valid only during an Ultra DMA data burst during a DMA Write command.
- 4) The HSTROBE and DSTROBE signals are active on both the rising and the falling edge.
- 5) Address lines 03 through 10 are not used in True IDE mode.

Ultra DMA Data Transfers Timing

Table 3-19 and Table 3-20 define the timings associated with all phases of Ultra DMA data bursts.

Table 3-19: Ultra DMA Data Burst Timing Requirements

| Name | UDMA Mode 0 | | UDMA Mode 1 | | UDMA Mode 2 | | UDMA Mode 3 | | UDMA Mode 4 | | UDMA Mode 5 | | Measure location ² |
|----------------------|-------------|-----|-------------|-----|-------------|-----|-------------|-----|-------------|-----|-------------|-----|-------------------------------|
| | Min | Max | Min | Max | Min | Max | Min | Max | Min | Max | Min | Max | |
| t _{2CYCTYP} | 240 | | 160 | | 120 | | 90 | | 60 | | 40 | | Sender |
| t _{CYC} | 112 | | 73 | | 54 | | 39 | | 25 | | 16.8 | | Note 3 |
| t _{2CYC} | 230 | | 153 | | 115 | | 86 | | 57 | | 38 | | Sender |
| t _{DS} | 15.0 | | 10.0 | | 7.0 | | 7.0 | | 5.0 | | 4.0 | | Recipient |
| t _{DH} | 5.0 | | 5.0 | | 5.0 | | 5.0 | | 5.0 | | 4.6 | | Recipient |
| t _{DVS} | 70.0 | | 48.0 | | 31.0 | | 20.0 | | 6.7 | | 4.8 | | Sender |
| t _{DVH} | 6.2 | | 6.2 | | 6.2 | | 6.2 | | 6.2 | | 4.8 | | Sender |
| t _{CS} | 15.0 | | 10.0 | | 7.0 | | 7.0 | | 5.0 | | 5.0 | | Device |
| t _{CH} | 5.0 | | 5.0 | | 5.0 | | 5.0 | | 5.0 | | 5.0 | | Device |
| t _{CVS} | 70.0 | | 48.0 | | 31.0 | | 20.0 | | 6.7 | | 10.0 | | Host |
| t _{CVH} | 6.2 | | 6.2 | | 6.2 | | 6.2 | | 6.2 | | 10.0 | | Host |
| t _{ZFS} | 0 | | 0 | | 0 | | 0 | | 0 | | 35 | | Device |
| t _{DZFS} | 70.0 | | 48.0 | | 31.0 | | 20.0 | | 6.7 | | 25 | | Sender |
| t _{FS} | | 230 | | 200 | | 170 | | 130 | | 120 | | 90 | Device |
| t _{LI} | 0 | 150 | 0 | 150 | 0 | 150 | 0 | 100 | 0 | 100 | 0 | 75 | Note 4 |
| t _{MLI} | 20 | | 20 | | 20 | | 20 | | 20 | | 20 | | Host |
| t _{UI} | 0 | | 0 | | 0 | | 0 | | 0 | | 0 | | Host |
| t _{AZ} | | 10 | | 10 | | 10 | | 10 | | 10 | | 10 | Note 5 |
| t _{ZAH} | 20 | | 20 | | 20 | | 20 | | 20 | | 20 | | Host |
| t _{ZAD} | 0 | | 0 | | 0 | | 0 | | 0 | | 0 | | Device |
| t _{ENV} | 20 | 70 | 20 | 70 | 20 | 70 | 20 | 55 | 20 | 55 | 20 | 50 | Host |
| t _{RFS} | | 75 | | 70 | | 60 | | 60 | | 60 | | 50 | Sender |
| t _{RP} | 160 | | 125 | | 100 | | 100 | | 100 | | 85 | | Recipient |
| t _{IORDYZ} | | 20 | | 20 | | 20 | | 20 | | 20 | | 20 | Device |
| t _{ZIORDY} | 0 | | 0 | | 0 | | 0 | | 0 | | 0 | | Device |
| t _{ACK} | 20 | | 20 | | 20 | | 20 | | 20 | | 20 | | Host |
| t _{SS} | 50 | | 50 | | 50 | | 50 | | 50 | | 50 | | Sender |

Notes:

All Timings in ns

1) All timing measurement switching points (low to high and high to low) shall be taken at 1.5 V.

2) All signal transitions for a timing parameter shall be measured at the connector specified in the measurement

location column. For example, in the case of tRFS, both STROBE and -DMARDY transitions are measured at the sender connector.

3) The parameter t_{CYC} shall be measured at the recipient's connector farthest from the sender.

4) The parameter t_{LI} shall be measured at the connector of the sender or recipient that is responding to an incoming transition from the recipient or sender respectively. Both the incoming signal and the outgoing response shall be measured at the same connector.

5) The parameter tAZ shall be measured at the connector of the sender or recipient that is driving the bus but must release the bus to allow for a bus turnaround.

6) See the AC Timing requirements in Table 3-21: Ultra DMA AC Signal Requirements.

Table 3-20: Ultra DMA Data Burst Timing Descriptions

| NAME | COMMENT | NOTES |
|----------|---|-------|
| t2CYCTYP | Typical sustained average two cycle time | |
| tCYC | Cycle time allowing for asymmetry and clock variations (from STROBE edge to STROBE edge) | |
| t2CYC | Two cycle time allowing for clock variations (from rising edge to next rising edge or from falling edge to next falling edge of STROBE) | |
| tDS | Data setup time at recipient (from data valid until STROBE edge) | 2, 5 |
| tDH | Data hold time at recipient (from STROBE edge until data may become invalid) | 2, 5 |
| tDVS | Data valid setup time at sender (from data valid until STROBE edge) | 3 |
| tDVH | Data valid hold time at sender (from STROBE edge until data may become invalid) | 3 |
| tCS | CRC word setup time at device | 2 |
| tCH | CRC word hold time device | 2 |
| tCVS | CRC word valid setup time at host (from CRC valid until -DMACK negation) | 3 |
| tCVH | CRC word valid hold time at sender (from -DMACK negation until CRC may become invalid) | 3 |
| tZFS | Time from STROBE output released-to-driving until the first transition of critical timing. | |
| tDZFS | Time from data output released-to-driving until the first transition of critical timing. | |
| tFS | First STROBE time (for device to first negate DSTROBE from STOP during a data in burst) | |
| tLI | Limited interlock time | 1 |
| tMLI | Interlock time with minimum | 1 |
| tUI | Unlimited interlock time | 1 |
| tAZ | Maximum time allowed for output drivers to release (from asserted or negated) | |

| NAME | COMMENT | NOTES |
|---------|--|-------|
| tZAH | Minimum delay time required for output | |
| tZAD | drivers to assert or negate (from released) | |
| tENV | Envelope time (from -DMACK to STOP and -HDMARDY during data in burst initiation and from DMACK to STOP during data out burst initiation) | |
| tRFS | Ready-to-final-STROBE time (no STROBE edges shall be sent this long after negation of -DMARDY) | |
| tRP | Ready-to-pause time (that recipient shall wait to pause after negating -DMARDY) | |
| tIORDYZ | Maximum time before releasing IORDY | 6 |
| tZIORDY | Minimum time before driving IORDY | 4, 6 |
| tACK | Setup and hold times for -DMACK (before assertion or negation) | |
| tSS | Time from STROBE edge to negation of DMARQ or assertion of STOP (when sender terminates a burst) | |

Notes:

- 1) The parameters t_{UI} , t_{MLI} (in Figure 3-12: Ultra DMA Data-In Burst Device Termination Timing and Figure 3-13: Ultra DMA Data-In Burst Host Termination Timing), and t_{LI} indicate sender-to-recipient or recipient-to-sender interlocks, i.e., one agent (either sender or recipient) is waiting for the other agent to respond with a signal before proceeding. t_{UI} is an unlimited interlock that has no maximum time value. t_{MLI} is a limited time-out that has a defined minimum. t_{LI} is a limited time-out that has a defined maximum.
- 2) 80-conductor cabling (see 4.3.8.4) shall be required in order to meet setup (t_{DS} , t_{CS}) and hold (t_{DH} , t_{CH}) times in modes greater than 2.
- 3) Timing for t_{DVS} , t_{DVH} , t_{CVS} and t_{CVH} shall be met for lumped capacitive loads of 15 and 40 pF at the connector where the Data and STROBE signals have the same capacitive load value. Due to reflections on the cable, these timing measurements are not valid in a normally functioning system.
- 4) For all timing modes the parameter t_{ZIORDY} may be greater than t_{ENV} due to the fact that the host has a pull-up on IORDY- giving it a known state when released.
- 5) The parameters t_{DS} , and t_{DH} for mode 5 are defined for a recipient at the end of the cable only in a configuration with a single device located at the end of the cable. This could result in the minimum values for t_{DS} and t_{DH} for mode 5 at the middle connector being 3.0 and 3.9 ns respectively.
- 6) This parameter applies to True IDE mode operation only.

Table 3-21: Ultra DMA Sender and Recipient IC Timing Requirements

| Name | UDMA Mode 0 (ns) | | UDMA Mode 1 (ns) | | UDMA Mode 2 (ns) | | UDMA Mode 3 (ns) | | UDMA Mode 4 (ns) | | UDMA Mode 5 (ns) | |
|--------|--|-----|------------------|-----|------------------|-----|------------------|-----|------------------|-----|------------------|-----|
| | Min | Max | Min | Max | Min | Max | Min | Max | Min | Max | Min | Max |
| tDSIC | 14.7 | | 9.7 | | 6.8 | | 6.8 | | 4.8 | | 2.3 | |
| tDHIC | 4.8 | | 4.8 | | 4.8 | | 4.8 | | 4.8 | | 2.8 | |
| tDVSIC | 72.9 | | 50.9 | | 33.9 | | 22.6 | | 9.5 | | 6.0 | |
| tDVHIC | 9.0 | | 9.0 | | 9.0 | | 9.0 | | 9.0 | | 6.0 | |
| tDSIC | Recipient IC data setup time (from data valid until STROBE edge) (see note 2) | | | | | | | | | | | |
| tDHIC | Recipient IC data hold time (from STROBE edge until data may become invalid) (see note 2) | | | | | | | | | | | |
| tDVSIC | Sender IC data valid setup time (from data valid until STROBE edge) (see note 3) | | | | | | | | | | | |
| tDVHIC | Sender IC data valid hold time (from STROBE edge until data may become invalid) (see note 3) | | | | | | | | | | | |

Notes:

- 1) All timing measurement switching points (low to high and high to low) shall be taken at 1.5 V.
- 2) The correct data value shall be captured by the recipient given input data with a slew rate of 0.4 V/ns rising and falling and the input STROBE with a slew rate of 0.4 V/ns rising and falling at tDSIC and tDHIC timing (as measured through 1.5 V).
- 3) The parameters tDVSIC and tDVHIC shall be met for lumped capacitive loads of 15 and 40 pF at the IC where all signals have the same capacitive load value. Noise that may couple onto the output signals from external sources has not been included in these values.

Initiating an Ultra DMA Data-In Burst

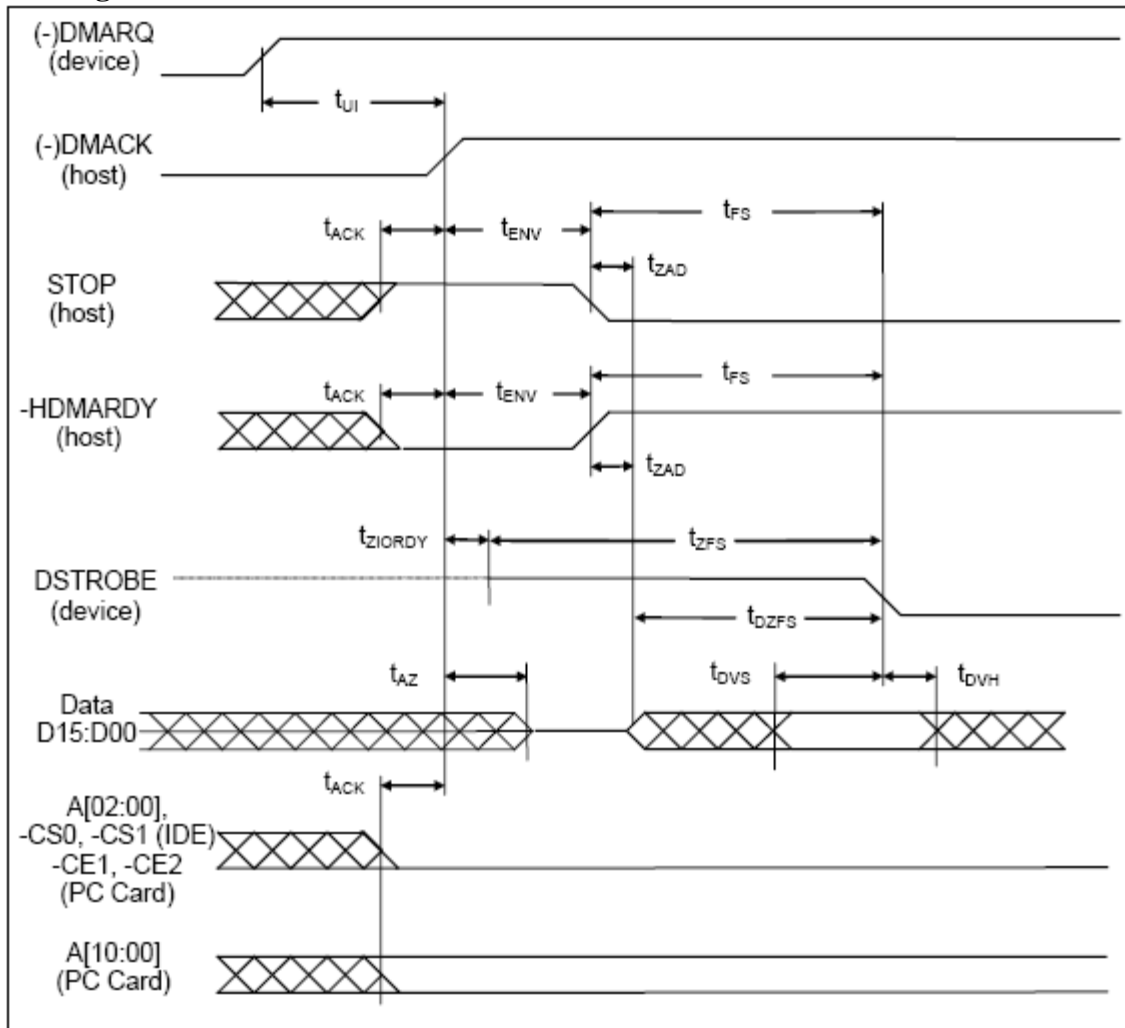

ALL WAVEFORMS IN THIS DIAGRAM ARE SHOWN WITH THE ASSERTED STATE HIGH. NEGATIVE TRUE SIGNALS APPEAR INVERTED ON THE BUS RELATIVE TO THE DIAGRAM.

Notes:

The definitions for the IORDY:-DDMARDY:DSTROBE, -IORD: -HDMARDY:HSTROBE, and -IOWR:STOP signal lines are not in effect until DMARQ and -DMACK are asserted. A[02:00], -CS0 & -CS1 are True IDE mode signal definitions. A[10:00], -CE1 and -CE2 are PC Card mode signals. The Bus polarity of (-)DMACK and (-)DMARQ are dependent on interface mode active.

Figure 3-9: Ultra DMA Data-In Burst Initiation Timing

Sustaining an Ultra DMA Data-In Burst

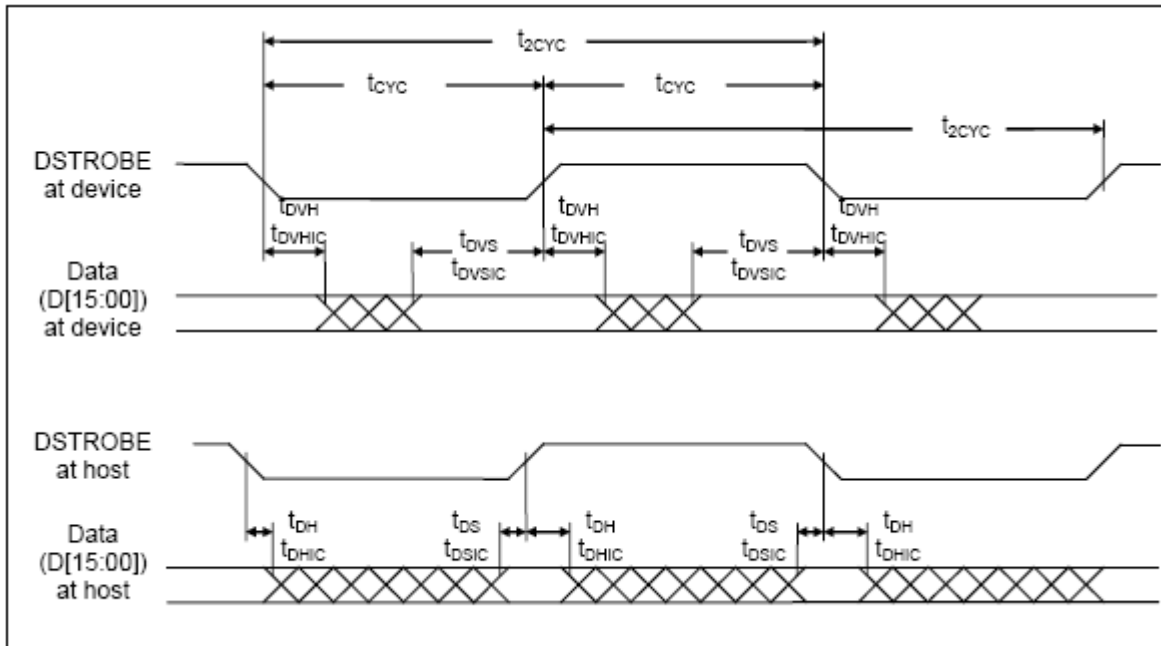

ALL WAVEFORMS IN THIS DIAGRAM ARE SHOWN WITH THE ASSERTED STATE HIGH. NEGATIVE TRUE SIGNALS APPEAR INVERTED ON THE BUS RELATIVE TO THE DIAGRAM.

Notes:

D[15:00] and DSTROBE signals are shown at both the host and the device to emphasize that cable settling time as well as cable propagation delay shall not allow the data signals to be considered stable at the host until some time after they are driven by the device.

Figure 3-10: Sustained Ultra DMA Data-In Burst Timing

Host Pausing an Ultra DMA Data-In Burst

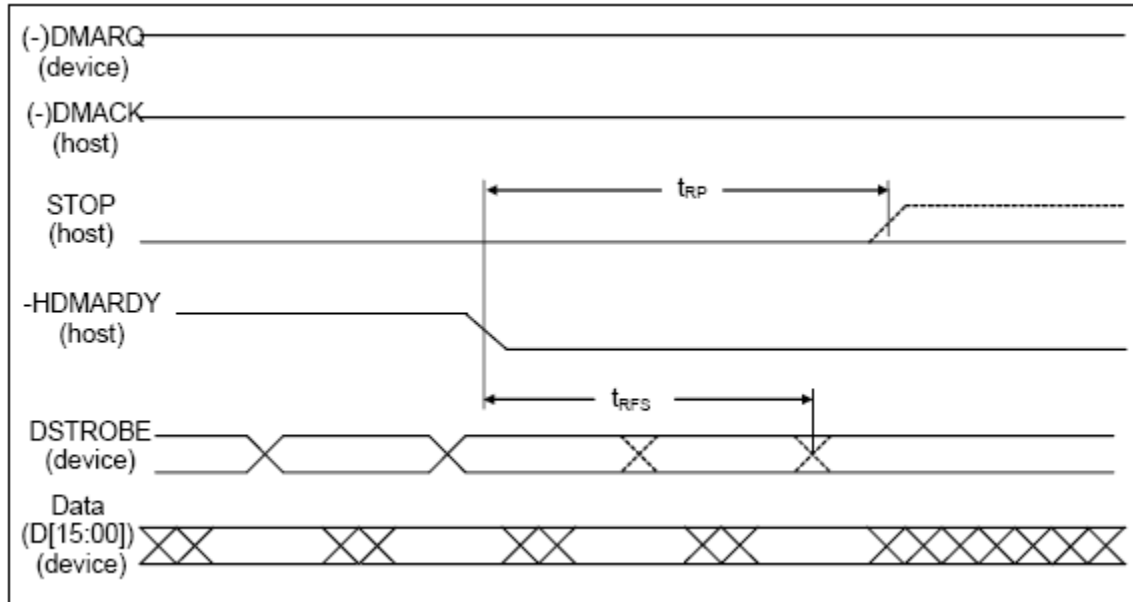

ALL WAVEFORMS IN THIS DIAGRAM ARE SHOWN WITH THE ASSERTED STATE HIGH. NEGATIVE TRUE SIGNALS APPEAR INVERTED ON THE BUS RELATIVE TO THE DIAGRAM.

Notes:

- 1) The host may assert STOP to request termination of the Ultra DMA data burst no sooner than t_{RP} after $-HDMARDY$ is negated.
- 2) After negating $-HDMARDY$, the host may receive zero, one, two, or three more data words from the device.
- 3) The bus polarity of the (-) DMARQ and (-)DMACK signals is dependent on the active interface mode.

Figure 3-11: Ultra DMA Data-In Burst Host Pause Timing

Device Terminating an Ultra DMA Data-In Burst

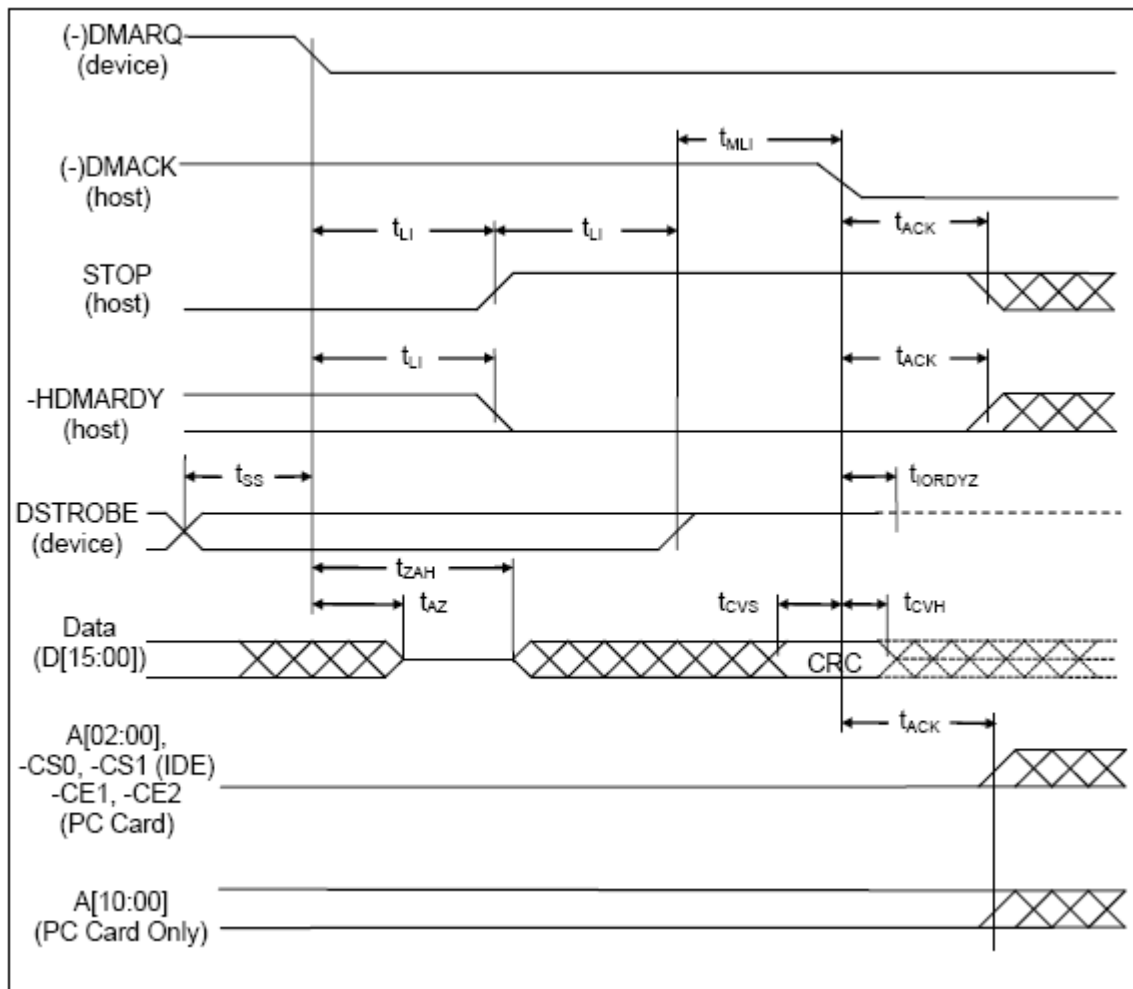

ALL WAVEFORMS IN THIS DIAGRAM ARE SHOWN WITH THE ASSERTED STATE HIGH. NEGATIVE TRUE SIGNALS APPEAR INVERTED ON THE BUS RELATIVE TO THE DIAGRAM.

Notes:

The definitions for the STOP, HDMARDY, and DSTROBE signal lines are no longer in effect after DMARQ and DMACK are negated. A[02:00], -CS0 & -CS1 are True IDE mode signal definitions. A[10:00], -CE1 and -CE2 are PC Card mode signals. The bus polarity of DMARQ and DMACK are dependent on the active interface mode.

Figure 3-12: Ultra DMA Data-In Burst Device Termination Timing

Host Terminating an Ultra DMA Data-In Burst

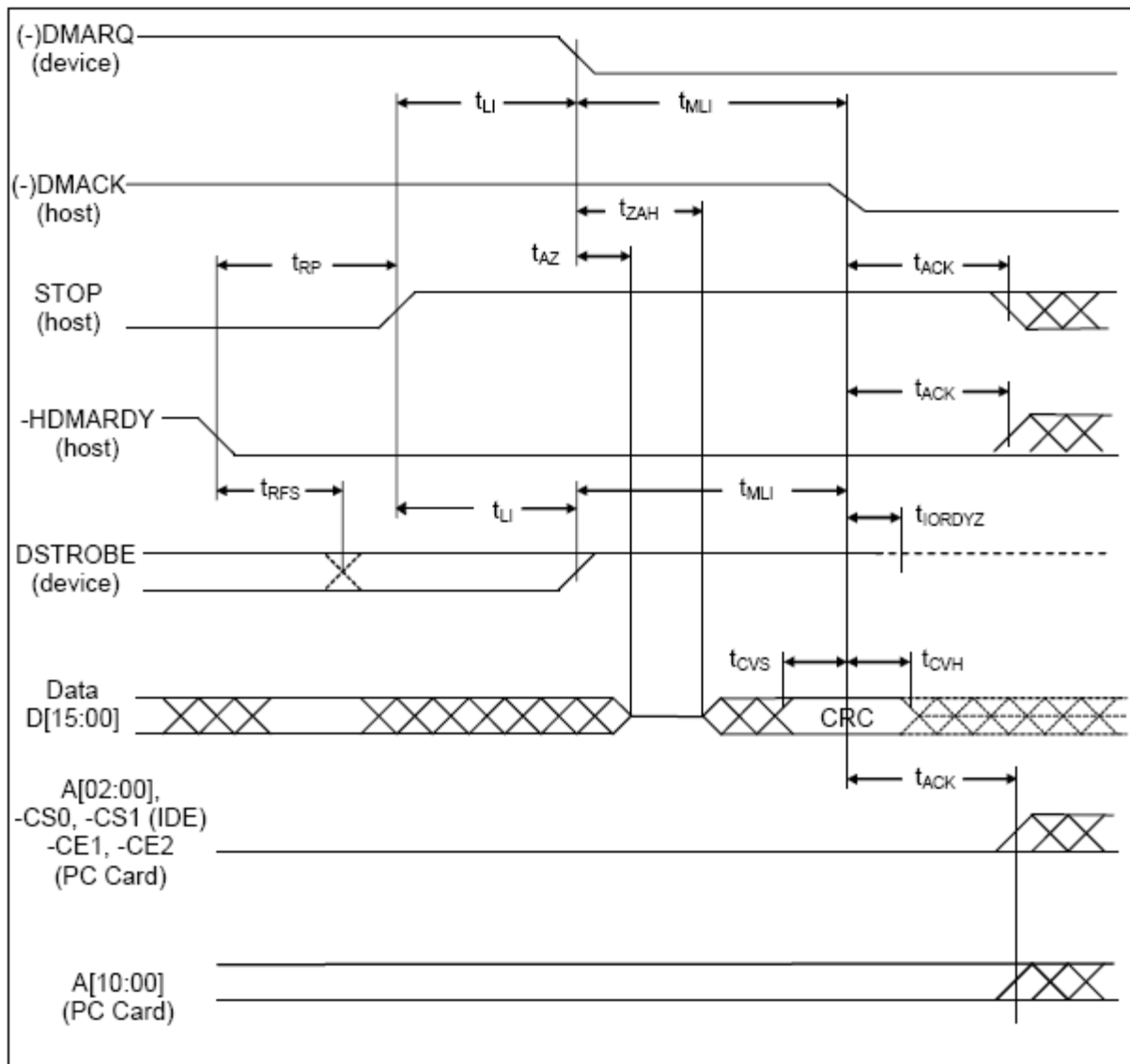

ALL WAVEFORMS IN THIS DIAGRAM ARE SHOWN WITH THE ASSERTED STATE HIGH. NEGATIVE TRUE SIGNALS APPEAR INVERTED ON THE BUS RELATIVE TO THE DIAGRAM.

Notes:

The definitions for the STOP, HDMARDY, and DSTROBE signal lines are no longer in effect after DMARQ and DMACK are negated. A[02:00], -CS0 & -CS1 are True IDE mode signal definitions. A[10:00], -CE1 and -CE2 are PC Card mode signal definitions. The bus polarity of DMARQ and DMACK depend on the active interface mode.

Figure 3-13: Ultra DMA Data-In Burst Host Termination Timing

Initiating an Ultra DMA Data-Out Burst

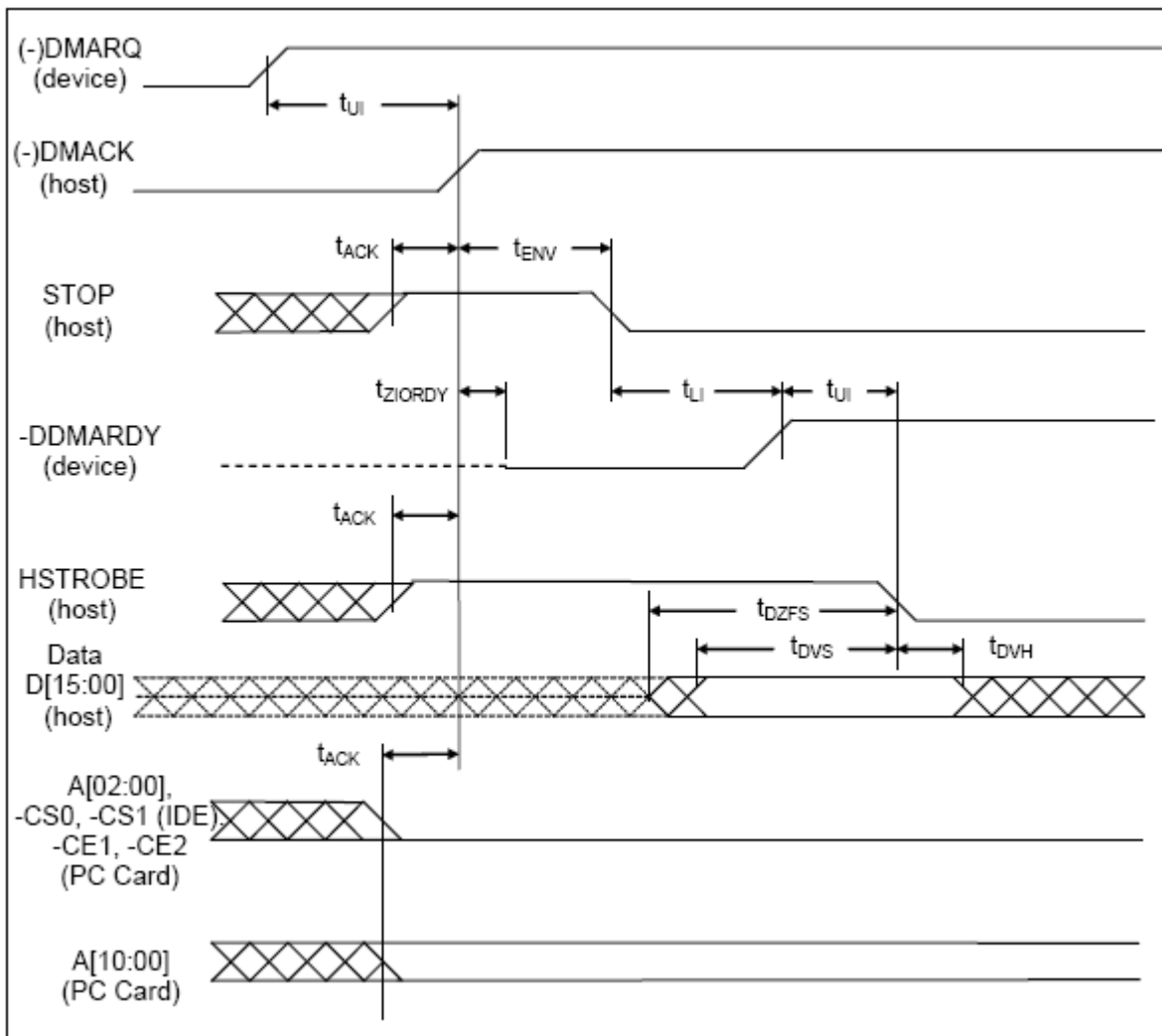

ALL WAVEFORMS IN THIS DIAGRAM ARE SHOWN WITH THE ASSERTED STATE HIGH. NEGATIVE TRUE SIGNALS APPEAR INVERTED ON THE BUS RELATIVE TO THE DIAGRAM.

Note:

The definitions for the STOP, DDMARDY, and HSTROBE signal lines are not in effect until DMARQ and DMACK are asserted. A[02:00], -CS0 & -CS1 are True IDE mode signal definitions. A[10:00], -CE1 and -CE2 are PC Card mode signal definitions. The bus polarity of DMARQ and DMACK depend on the active interface mode.

Figure 3-14: Ultra DMA Data-Out Burst Initiation Timing

Sustaining an Ultra DMA Data-Out Burst

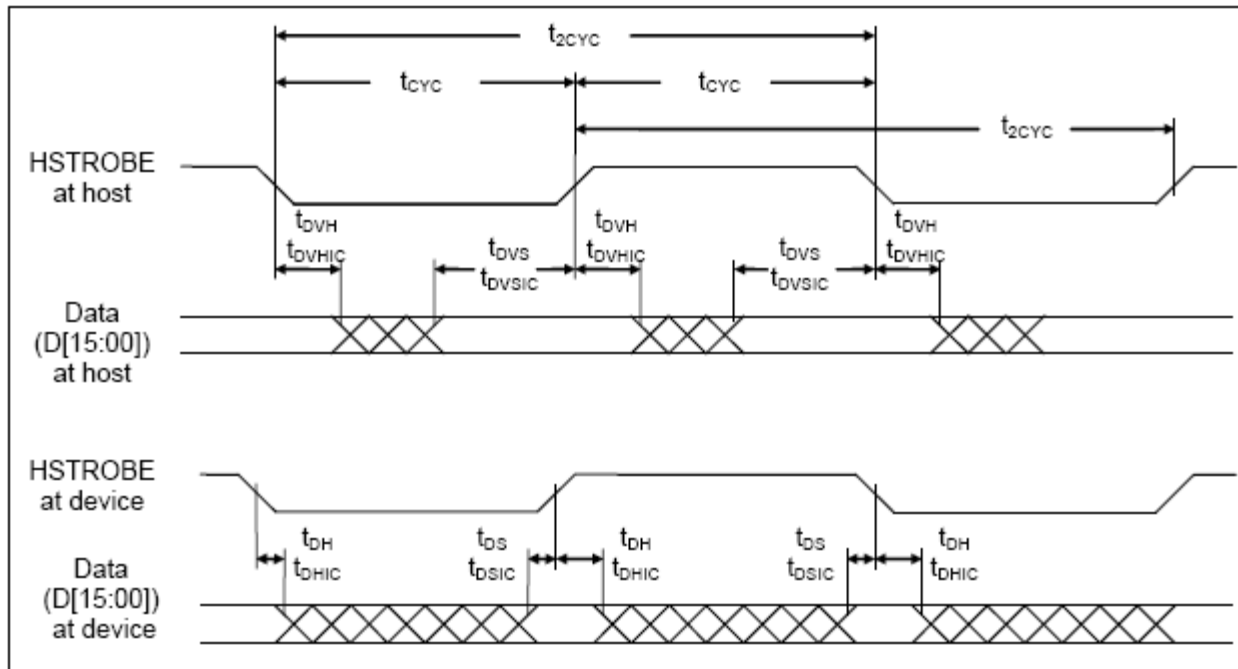

ALL WAVEFORMS IN THIS DIAGRAM ARE SHOWN WITH THE ASSERTED STATE HIGH. NEGATIVE TRUE SIGNALS APPEAR INVERTED ON THE BUS RELATIVE TO THE DIAGRAM.

Note:

Data (D[15:00]) and HSTROBE signals are shown at both the device and the host to emphasize that cable settling time as well as cable propagation delay shall not allow the data signals to be considered stable at the device until some time after they are driven by the host.

Figure 3-15: Sustained Ultra DMA Data-Out Burst Timing

Device Pausing an Ultra DMA Data-Out Burst

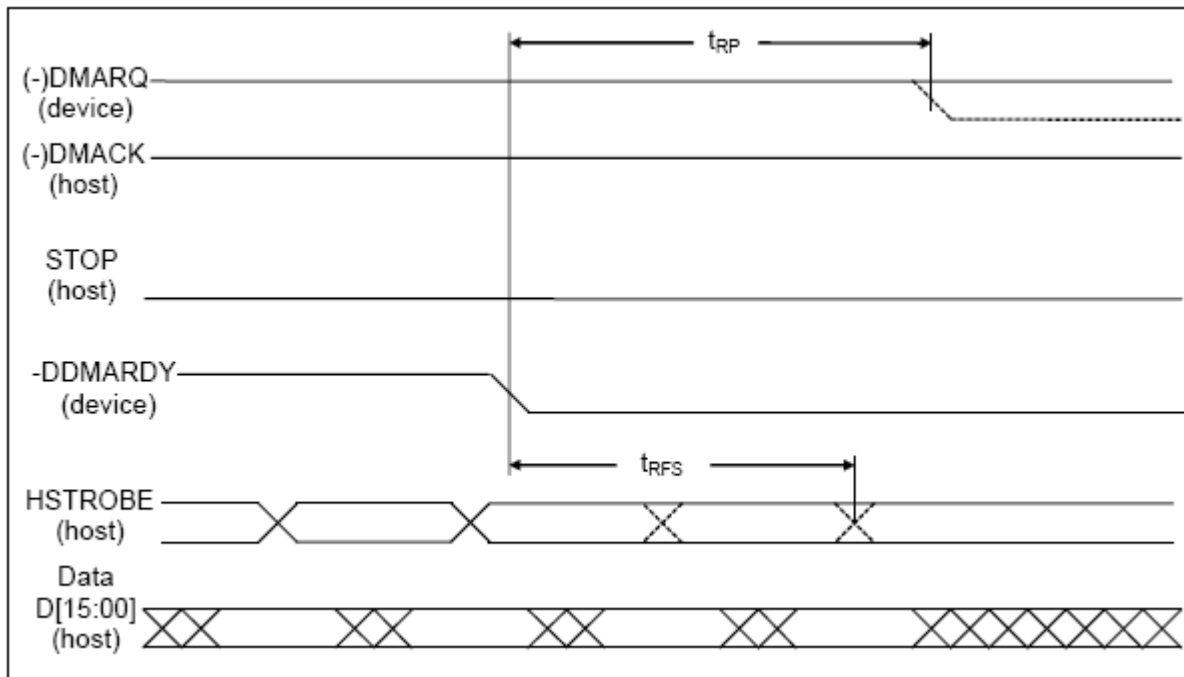

ALL WAVEFORMS IN THIS DIAGRAM ARE SHOWN WITH THE ASSERTED STATE HIGH. NEGATIVE TRUE SIGNALS APPEAR INVERTED ON THE BUS RELATIVE TO THE DIAGRAM.

Notes:

- 1) The device may negate DMARQ to request termination of the Ultra DMA data burst no sooner than t_{RP} after -DDMARDY is negated.
- 2) After negating -DDMARDY, the device may receive zero, one, two, or three more data words from the host.
- 3) The bus polarity of DMARQ and DMACK depend on the active interface mode.

Figure 3-16: Ultra DMA Data-Out Burst Device Pause Timing

Device Terminating an Ultra DMA Data-Out Burst

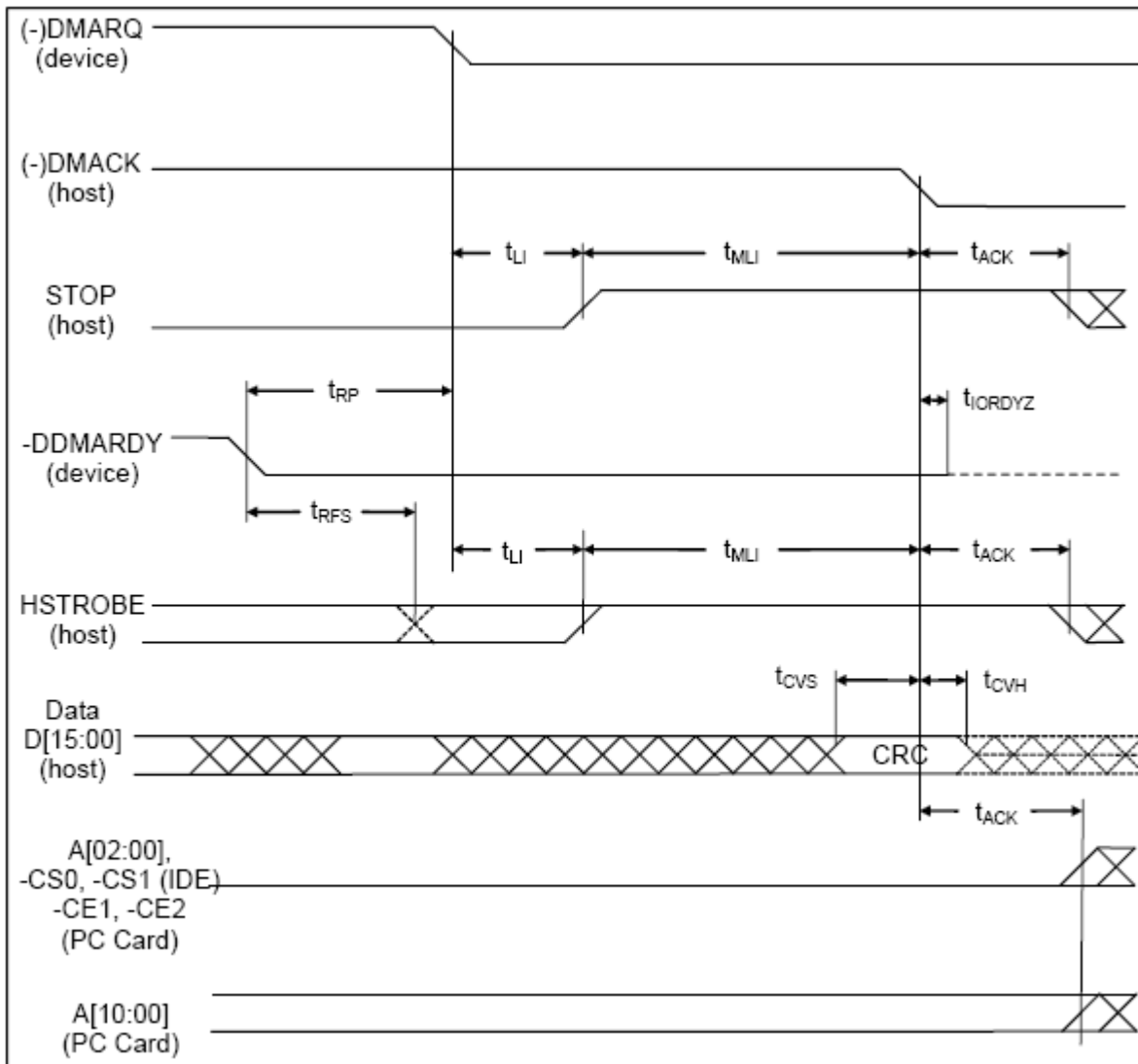

ALL WAVEFORMS IN THIS DIAGRAM ARE SHOWN WITH THE ASSERTED STATE HIGH. NEGATIVE TRUE SIGNALS APPEAR INVERTED ON THE BUS RELATIVE TO THE DIAGRAM.

Note:

The definitions for the STOP, DDMARDY, and HSTROBE signal lines are no longer in effect after DMARQ and DMACK are negated. A00-A02, -CS0 & -CS1 are True IDE mode signal definitions. A00-A10, -CE1 and -CE2 are PC Card mode signals. The bus polarity of DMARQ and DMACK depend on the active interface mode.

Figure 3-17: Ultra DMA Data-Out Burst Device Termination Timing

Host Terminating an Ultra DMA Data-Out Burst

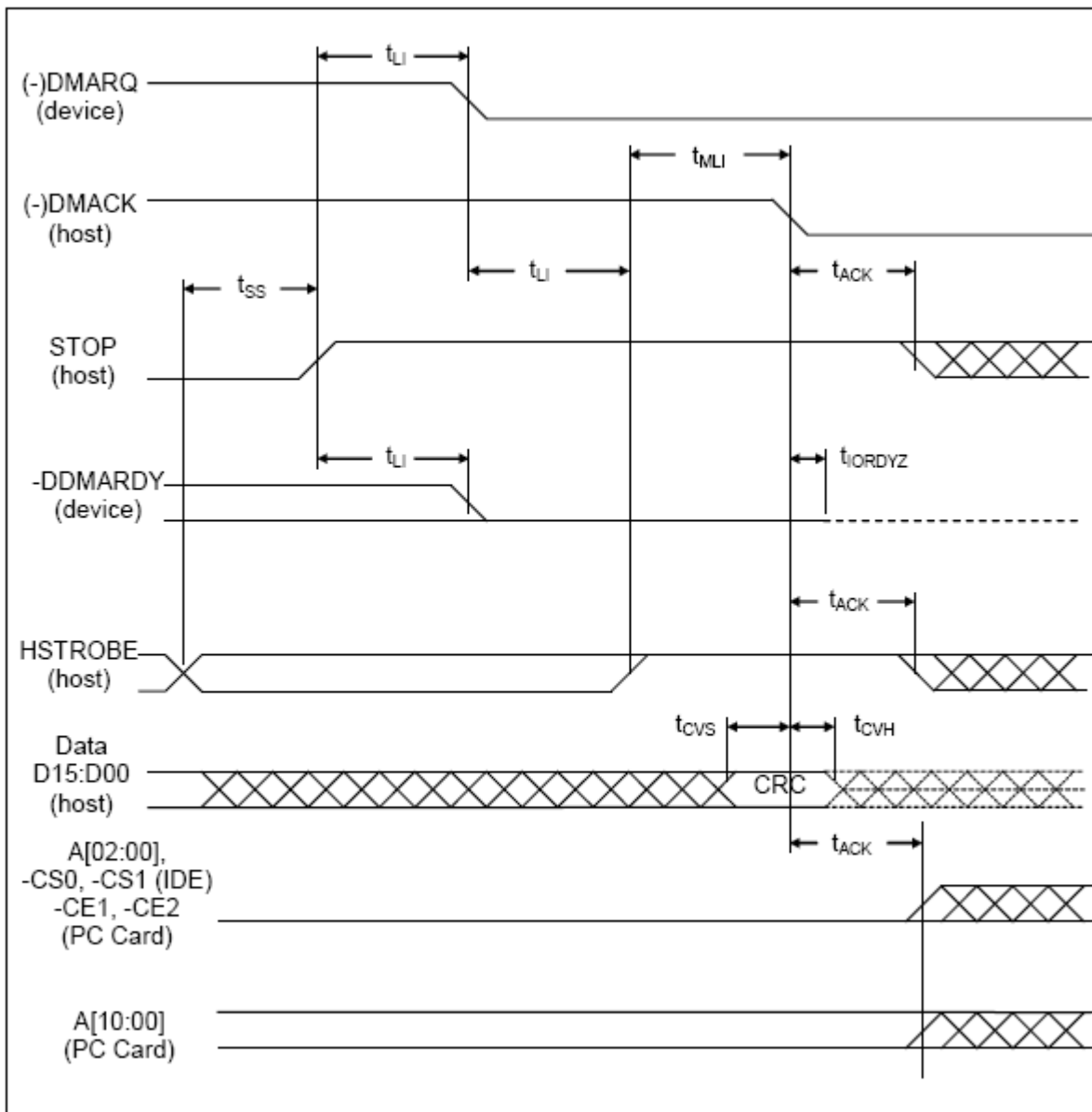

ALL WAVEFORMS IN THIS DIAGRAM ARE SHOWN WITH THE ASSERTED STATE HIGH. NEGATIVE TRUE SIGNALS APPEAR INVERTED ON THE BUS RELATIVE TO THE DIAGRAM.

Notes:

The definitions for the STOP, DDMARDY, and HSTROBE signal lines are no longer in effect after DMARQ and DMACK are negated. A[02:00], -CS0 & -CS1 are True IDE mode signal definitions. A[10:00], -CE1 and -CE2 are PC Card mode signal definitions. The bus polarity of DMARQ and DMACK depend on the active interface mode.

Figure 3-18: Ultra DMA Data-Out Burst Host Termination Timing

Ultra DMA CRC Calculation

Table 3-22: Equations for parallel generation of an Ultra DMA CRC

| | |
|--|---|
| $CRCIN0 = f16$ | $CRCIN8 = f8 \text{ XOR } f13$ |
| $CRCIN1 = f15$ | $CRCIN9 = f7 \text{ XOR } f12$ |
| $CRCIN2 = f14$ | $CRCIN10 = f6 \text{ XOR } f11$ |
| $CRCIN3 = f13$ | $CRCIN11 = f5 \text{ XOR } f10$ |
| $CRCIN4 = f12$ | $CRCIN12 = f4 \text{ XOR } f9 \text{ XOR } f16$ |
| $CRCIN5 = f11 \text{ XOR } f16$ | $CRCIN13 = f3 \text{ XOR } f8 \text{ XOR } f15$ |
| $CRCIN6 = f10 \text{ XOR } f15$ | $CRCIN14 = f2 \text{ XOR } f7 \text{ XOR } f14$ |
| $CRCIN7 = f9 \text{ XOR } f14$ | $CRCIN15 = f1 \text{ XOR } f6 \text{ XOR } f13$ |
| $f1 = D00 \text{ XOR } CRCOUT15$ | $f9 = D08 \text{ XOR } CRCOUT7 \text{ XOR } f5$ |
| $f2 = D01 \text{ XOR } CRCOUT14$ | $f10 = D09 \text{ XOR } CRCOUT6 \text{ XOR } f6$ |
| $f3 = D02 \text{ XOR } CRCOUT13$ | $f11 = D10 \text{ XOR } CRCOUT5 \text{ XOR } f7$ |
| $f4 = D03 \text{ XOR } CRCOUT12$ | $f12 = D11 \text{ XOR } CRCOUT4 \text{ XOR } f1 \text{ XOR } f8$ |
| $f5 = D04 \text{ XOR } CRCOUT11 \text{ XOR } f1$ | $f13 = D12 \text{ XOR } CRCOUT3 \text{ XOR } f2 \text{ XOR } f9$ |
| $f6 = D05 \text{ XOR } CRCOUT10 \text{ XOR } f2$ | $f14 = D13 \text{ XOR } CRCOUT2 \text{ XOR } f3 \text{ XOR } f10$ |
| $f7 = D06 \text{ XOR } CRCOUT9 \text{ XOR } f3$ | $f15 = D14 \text{ XOR } CRCOUT1 \text{ XOR } f4 \text{ XOR } f11$ |
| $f8 = D07 \text{ XOR } CRCOUT8 \text{ XOR } f4$ | $f16 = D15 \text{ XOR } CRCOUT0 \text{ XOR } f5 \text{ XOR } f12$ |

Notes:

- 1) f=feedback
 - 2) D[15:0] = Data to or from the bus
 - 3) CRCOUT = 16-bit edge triggered result (current CRC)
 - 4) CRCOUT[15:0] are sent on matching order bits of D[15:00]
- An example of a CRC generator implementation is provided below in Figure 3-19: Ultra DMA Parallel CRC Generator Example.

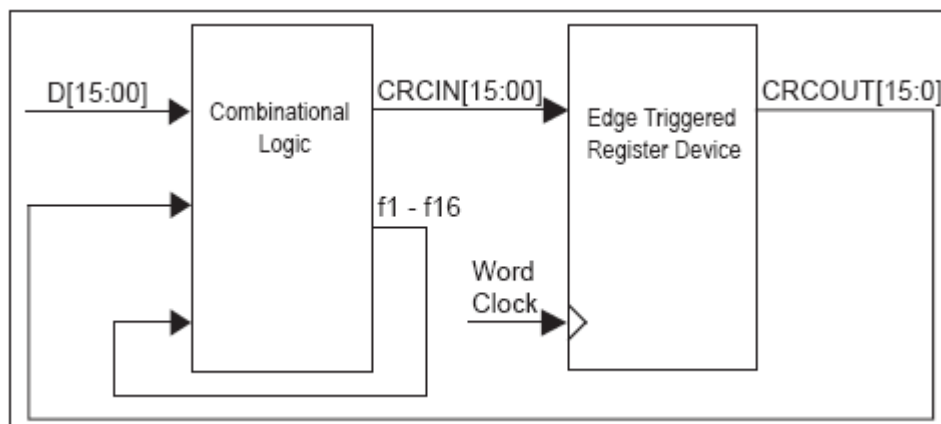

Figure 3-19: Ultra DMA Parallel CRC Generator Example

3.4 Card Configuration

The CompactFlash Storage Cards are identified by appropriate information in the Card Information Structure (CIS). The following configuration registers are used to coordinate the I/O spaces and the Interrupt level of cards that are located in the system. In addition, these registers provide a method for accessing status information about the CompactFlash Storage Card that may be used to arbitrate between multiple interrupt sources on the same interrupt level or to replace status information that appears on dedicated pins in memory cards that have alternate use in I/O cards.

3.4.1 CompactFlash Storage Card Registers and Memory Space Decoding

Table 3-23: CompactFlash Storage Card Registers and Memory Space Decoding

| -CE2 | -CE1 | -REG | -OE | -WE | A10 | A9 | A8-A4 | A3 | A2 | A1 | A0 | SELECTED SPACE |
|------|------|------|-----|-----|-----|----|-------|----|----|----|----|--------------------------------------|
| 1 | 1 | X | X | X | X | X | XX | X | X | X | X | Standby and UDMA transfer |
| X | 0 | 0 | 0 | 1 | 0 | 1 | XX | X | X | X | 0 | Configuration Registers Read |
| 1 | 0 | 1 | 0 | 1 | X | X | XX | X | X | X | X | Common Memory Read (8 Bit D7-D0) |
| 0 | 1 | 1 | 0 | 1 | X | X | XX | X | X | X | X | Common Memory Read (8 Bit D15-D8) |
| 0 | 0 | 1 | 0 | 1 | X | X | XX | X | X | X | 0 | Common Memory Read (16 Bit D15-D0) |
| X | 0 | 0 | 1 | 0 | 0 | 1 | XX | X | X | X | 0 | Configuration Registers Write |
| 1 | 0 | 1 | 1 | 0 | X | X | XX | X | X | X | X | Common Memory Write (8 Bit D7-D0) |
| 0 | 1 | 1 | 1 | 0 | X | X | XX | X | X | X | X | Common Memory Write (8 Bit D15-D8) |
| 0 | 0 | 1 | 1 | 0 | X | X | XX | X | X | X | 0 | Common Memory Write (16 Bit D15-D0) |
| X | 0 | 0 | 0 | 1 | 0 | 0 | XX | X | X | X | 0 | Card Information Structure Read |
| 1 | 0 | 0 | 1 | 0 | 0 | 0 | XX | X | X | X | 0 | Invalid Access (CIS Write) |
| 1 | 0 | 0 | 0 | 1 | X | X | XX | X | X | X | 1 | Invalid Access (Odd Attribute Read) |
| 1 | 0 | 0 | 1 | 0 | X | X | XX | X | X | X | 1 | Invalid Access (Odd Attribute Write) |
| 0 | 1 | 0 | 0 | 1 | X | X | XX | X | X | X | X | Invalid Access (Odd Attribute Read) |
| 0 | 1 | 0 | 1 | 0 | X | X | XX | X | X | X | X | Invalid Access (Odd Attribute Write) |

Table 3-24: PC Card Memory Mode UDMA Function

| -CE2 | -CE1 | -DMARQ -INPACK | -DMACK - REG | STOP -IOWR | -DMARDY -IORD (R) -WAIT (W) | STROBE -WAIT (R) -IORD (W) | DMA CMD | A10-A00 | OPERATION |
|------|------|-------------------|-----------------|---------------|-----------------------------------|----------------------------------|------------|---------|--|
| 1 | 1 | 1 | X | X | X | X | No | XX | Standby |
| X | X | 0 | 1 | X | X | 1 | YES | XX | Device UDMA Transfer Request (Assert DMARQ) |
| X | X | 0 | 1 | 1 | X | 1 | YES | XX | Host Acknowledge Preparation |
| 1 | 1 | 0 | 1 | 1 | 1 | 1 | YES | Static | Host Acknowledge Preparation |
| 1 | 1 | 0 | 0 | 1 | 1 | 1 | YES | Static | DMA Acknowledge (Stopped) |
| 1 | 1 | 0 | 0 | 0 | 0 | 1 | YES | Static | Burst Initiation / Active |
| 1 | 1 | 0 | 0 | 0 | X | / or \ | YES | Static | Burst Transfer |
| 1 | 1 | 0 | 0 | 0 | 1 | 0 or 1 | RD | Static | Data In Burst Host Pause |
| 1 | 1 | 0 | 0 | 0 | 0 | 0 or 1 | RD | Static | Data In Burst Device Pause |
| 1 | 1 | 0 | 0 | 0 | 1 | 0 or 1 | WR | Static | Data Out Burst Device Pause |
| 1 | 1 | 0 | 0 | 0 | 0 | 0 or 1 | WR | Static | Data Out Burst Host Pause |
| 1 | 1 | 1 | 0 | 0 | 0 | 0 or 1 | RD | Static | Device Initiating Burst Termination |
| 1 | 1 | 1 | 0 | 1 | 1 | 0 or 1 | RD | Static | Host Acknowledgement of Device Initiated Burst Termination |
| 1 | 1 | 0 | 0 | 1 | 0 | 0 or 1 | YES | Static | Host Initiating Burst Termination |
| 1 | 1 | 1 | 0 | 1 | 1 | 0 or 1 | YES | Static | Device Acknowledging Host Initiated Burst Termination |
| 1 | 1 | 1 | 0 | 1 | 1 | / | YES | Static | Device Aligning STROBE to Asserted before CRC Transfer |
| 1 | 1 | 1 | / | 1 | 1 | 1 | YES | Static | CRC Data Transfer for UDMA Burst |
| 1 | 1 | 1 | 1 | 1 | 1 | 1 | YES | Static | Burst Completed |

Table 3-25: CompactFlash Storage Card Configuration Registers Decoding

| -CE2 | -CE1 | -REG | -OE | -WE | A10 | A9 | A8-A4 | A3 | A2 | A1 | A0 | SELECTED REGISTER |
|------|------|------|-----|-----|-----|----|-------|----|----|----|----|--------------------------------|
| X | 0 | 0 | 0 | 1 | 0 | 1 | 00 | 0 | 0 | 0 | 0 | Configuration Option Reg Read |
| X | 0 | 0 | 1 | 0 | 0 | 1 | 00 | 0 | 0 | 0 | 0 | Configuration Option Reg Write |
| X | 0 | 0 | 0 | 1 | 0 | 1 | 00 | 0 | 0 | 1 | 0 | Card Status Register Read |
| X | 0 | 0 | 1 | 0 | 0 | 1 | 00 | 0 | 0 | 1 | 0 | Card Status Register Write |
| X | 0 | 0 | 0 | 1 | 0 | 1 | 00 | 0 | 1 | 0 | 0 | Pin Replacement Register Read |
| X | 0 | 0 | 1 | 0 | 0 | 1 | 00 | 0 | 1 | 0 | 0 | Pin Replacement Register Write |
| X | 0 | 0 | 0 | 1 | 0 | 1 | 00 | 0 | 1 | 1 | 0 | Socket and Copy Register Read |
| X | 0 | 0 | 1 | 0 | 0 | 1 | 00 | 0 | 1 | 1 | 0 | Socket and Copy Register Write |

3.4.2 Attribute Memory Function

Attribute memory is a space where CompactFlash Storage Card identification and configuration information are stored, and is limited to 8 bit wide accesses only at even addresses. The card configuration registers are also located here. For CompactFlash Storage Cards, the base address of the card configuration registers is 200h. For the Attribute Memory Read function, signals -REG and -OE shall be active and -WE inactive during the cycle. As in the Main Memory Read functions, the signals -CE1 and -CE2 control the even-byte and odd-byte address, but only the even-byte data is valid during the Attribute Memory access. Refer to Table 3-26: Attribute Memory Function below for signal states and bus validity for the Attribute Memory function.

Table 3-26: Attribute Memory Function

| Function Mode | DMA CMD | -REG | -CE2 | -CE1 | A10 | A9 | A0 | -OE | -WE | D15-D8 | D7-D0 |
|--|------------|----------------|----------------|----------------|-----|----|----|----------------|----------------|------------|-----------|
| Standby Mode | Don't Care | H | H | H | X | X | X | X | X | High Z | High Z |
| Standby Mode | No | X | H | H | X | X | X | X | X | High Z | High Z |
| UDMA Operation: Ultra DMA Mode Read/Write (Timing Specification) | Yes | L ¹ | H | H | X | X | X | H | H | Odd Byte | Even Byte |
| Read Byte Access CIS ROM (8 bits) | No | L | H | L ² | L | L | L | L ² | H | High Z | Even Byte |
| Write Byte Access CIS (8 bits) (Invalid) | No | L | H | L ² | L | L | L | H | L ² | Don't Care | Even Byte |
| Read Byte Access Configuration CompactFlash Storage (8 bits) | No | L | H | L | L | H | L | L | H | High Z | Even Byte |
| Write Byte Access Configuration CompactFlash Storage (8 bits) | No | L | H | L | L | H | L | H | L | Don't Care | Even Byte |
| Read Byte Access Configuration CF+ (8 bits) | No | L | H | L | X | X | L | L | H | High Z | Even Byte |
| Write Byte Access Configuration CF+ (8 bits) | No | L | H | L | X | X | L | H | L | Don't Care | Even Byte |
| Read Word Access CIS (16 bits) | No | L | L ² | L ² | L | L | X | L ² | H | Not Valid | Even Byte |
| Write Word Access CIS (16 bits) (Invalid) | No | L | L ² | L ² | L | L | X | H | L ² | Don't Care | Even Byte |
| Read Word Access Configuration CompactFlash Storage (16 bits) | No | L | L ² | L ² | L | H | X | L ² | H | Not Valid | Even Byte |
| Write Word Access Configuration CompactFlash Storage (16 bits) | No | L | L ² | L ² | L | H | X | H | L ² | Don't Care | Even Byte |
| Read Word Access Configuration CF+ (16 bits) | No | L | L ² | L ² | X | X | X | L ² | H | Not Valid | Even Byte |
| Write Word Access Configuration CF+ (16 bits) | No | L | L ² | L ² | X | X | X | H | L ² | Don't Care | Even Byte |

Note:

- 1) In UDMA operation, the -REG (-DMACK) signal shall be asserted only in response to -DMARQ.
- 2) The -CE signal or both the -OE signal and the -WE signal shall be de-asserted between consecutive cycle operations.

3.4.3 Configuration Option Register (Base + 00h in Attribute Memory)

The Configuration Option Register is used to configure the cards interface, address decoding and interrupt and to issue a soft reset to the CompactFlash Card.

| OPERATION | D7 | D6 | D5 | D4 | D3 | D2 | D1 | D0 |
|-----------|--------|---------|-------|-------|-------|-------|-------|-------|
| R/W | SRESET | LevlREQ | Conf5 | Conf4 | Conf3 | Conf2 | Conf1 | Conf0 |

Figure 3-20: Configuration Option Register

Note:

Conf5 and Conf4 are written as zero (0).

Table 3-27: CompactFlash Card Configurations

| CONF5 | CONF4 | CONF3 | CONF2 | CONF1 | CONF0 | DISK CARD MODE |
|-------|-------|-------|-------|-------|-------|---|
| 0 | 0 | 0 | 0 | 0 | 0 | Memory Mapped |
| 0 | 0 | 0 | 0 | 0 | 1 | I/O Mapped, Any 16 byte system decoded boundary |
| 0 | 0 | 0 | 0 | 1 | 0 | I/O Mapped, 1F0h-1F7h/3F6h-3F7h |
| 0 | 0 | 0 | 0 | 1 | 1 | I/O Mapped, 170h-177h/376h-377h |

3.4.4 Card Configuration and Status Register (Base + 02h in Attribute Memory)

The Card Configuration and Status Register contains information about the Card's condition.

| OPERATION | D7 | D6 | D5 | D4 | D3 | D2 | D1 | D0 |
|-----------|---------|--------|-------|-----|-------|--------|-----|----|
| Read | Changed | SigChg | IOis8 | -XE | Audio | PwrDwn | Int | 0 |
| Write | 0 | SigChg | IOis8 | -XE | Audio | PwrDwn | 0 | 0 |

Figure 3-21: Card Configuration and Status Register

3.4.5 Pin Replacement Register (Base + 04h in Attribute Memory)

| Operation | D7 | D6 | D5 | D4 | D3 | D2 | D1 | D0 |
|-----------|----|----|--------|--------|----|----|--------|--------|
| Read | 0 | 0 | CReady | CWProt | 1 | 1 | RReady | WProt |
| Write | 0 | 0 | CReady | CWProt | 0 | 0 | MReady | MWProt |

Figure 3-22: Pin Replacement Register

Table 3-28: Pin Replacement Changed Bit/Mask Bit Values

| Initial Value of (C) Status | Written by Host | | Final "C" Bit | Comments |
|-----------------------------|-----------------|---------|---------------|-----------------|
| | "C" Bit | "M" Bit | | |
| 0 | X | 0 | 0 | Unchanged |
| 1 | X | 0 | 1 | Unchanged |
| X | 0 | 1 | 0 | Cleared by Host |
| X | 1 | 1 | 1 | Set by Host |

3.4.6 Socket and Copy Register (Base + 06h in Attribute Memory)

This register contains additional configuration information. This register is always written by the system before writing the card's Configuration Index Register.

| OPERATION | D7 | D6 | D5 | D4 | D3 | D2 | D1 | D0 |
|-----------|----------|----|----|-------------------|----|----|----|----|
| Read | Reserved | 0 | 0 | Obsolete1(Drive#) | 0 | 0 | 0 | 0 |
| Write | 0 | 0 | 0 | Obsolete1(Drive#) | X | X | X | X |

Figure 3-23: Socket and Copy Register

3.5 I/O Transfer Function

The I/O transfer to or from the CompactFlash Storage can be either 8 or 16 bits. When a 16 bit accessible port is addressed, the signal -IOIS16 is asserted by the CompactFlash Card. Otherwise, the -IOIS16 signal is de-asserted. When a 16 bit transfer is attempted, and the -IOIS16 signal is not asserted by the CompactFlash Card, the system shall generate a pair of 8 bit references to access the word's even byte and odd byte. The CompactFlash Card permits both 8 and 16 bit accesses to all of its I/O addresses, so -IOIS16 is asserted for all addresses to which the CompactFlash Card responds.

The CompactFlash Card may request the host to extend the length of an input cycle until data is ready by asserting the -WAIT signal at the start of the cycle.

Table 3-29: PCMCIA Mode I/O Function

| FUNCTION CODE | -REG | -CE2 | -CE1 | A0 | -IORD | -IOWR | D15-D8 | D7-D0 |
|--------------------------------|------|------|------|-----|-------|-------|--------------------------|-----------------------|
| Standby Mode | X | H | H | X | X | X | High Z | High Z |
| Byte Input Access (8 bits) | L L | H H | L L | L H | L L | H H | High Z High Z | Even-Byte Odd-Byte |
| Byte Output Access (8 bits) | L L | H H | L L | L H | H H | L L | Don't Care Don't Care | Even-Byte Odd-Byte |
| Word Input Access (16 bits) | L | L | L | L | L | H | Odd-Byte | Even-Byte |
| Word Output Access (16 bits) | L | L | L | L | H | L | Odd-Byte | Even-Byte |
| I/O Read Inhibit | H | X | X | X | L | H | Don't Care | Don't Care |
| I/O Write Inhibit | H | X | X | X | H | L | High Z | High Z |
| High Byte Input Only (8 bits) | L | L | H | X | L | H | Odd-Byte | High Z |
| High Byte Output Only (8 bits) | L | L | H | X | H | L | Odd-Byte | Don't Care |

3.6 Common Memory Transfer Function

The Common Memory transfer to or from the CompactFlash Storage can be either 8 or 16 bits. The CompactFlash Storage Card permits both 8 and 16 bit accesses to all of its Common Memory addresses. The CompactFlash Storage Card may request the host to extend the length of a memory write cycle or extend the length of a memory read cycle until data is ready by asserting the -WAIT signal at the start of the cycle.

Table 3-30: Common Memory Function

| FUNCTION CODE | -REG | -CE2 | -CE1 | A0 | -OE | -WE | D15-D8 | D7-D0 |
|------------------------------|------|------|------|----|-----|-----|--------------------------|-----------------------|
| Standby Mode | X | H | H | X | X | X | High Z | High Z |
| Byte Read Access (8 bits) | HH | HH | LL | LH | LL | HH | High Z High Z | Even-Byte Odd-Byte |
| Byte Write Access (8 bits) | HH | HH | LL | LH | HH | LL | Don't Care Don't Care | Even-Byte Odd-Byte |
| Word Read Access (16 bits) | H | L | L | X | L | H | Odd-Byte | Even-Byte |
| Word Write Access (16 bits) | H | L | L | X | H | L | Odd-Byte | Even-Byte |
| Odd Byte Read Only (8 bits) | H | L | H | X | L | H | Odd-Byte | High Z |
| Odd Byte Write Only (8 bits) | H | L | H | X | H | L | Odd-Byte | Don't Care |

3.7 True IDE Mode I/O Transfer Function

The CompactFlash Storage Card can be configured in a True IDE Mode of operation. The CompactFlash Storage Card is configured in this mode only when the -OE input signal is grounded by the host during the power off to power on cycle. CompactFlash Storage Cards support the following optional detection methods:

1. The card is permitted to monitor the -OE (-ATA SEL) signal at any time(s) and switch to PCMCIA mode upon detecting a high level on the pin.
2. The card is permitted to re-arbitrate the interface mode determination following a transition of the (-)RESET pin.
3. The card is permitted to monitor the -OE (-ATA SEL) signal at any time(s) and switch to True IDE mode upon detection of a continuous low level on pin for an extended period of time. Host implementers should not rely on any of these optional detection methods in their designs. In the True IDE Mode, the PCMCIA protocol and configuration are disabled and only I/O operations to the Task File and Data Register are allowed. In this mode, no Memory or Attribute Registers are accessible to the host. CompactFlash Storage Cards permit 8 bit PIO mode data accesses if the user issues a Set Feature Command to put the CompactFlash Storage Card in 8 bit Mode.

Note:

Removing and reinserting the CompactFlash Storage Card while the host computer's power is on will reconfigure the CompactFlash Storage Card to PC Card ATA mode from the original True IDE Mode. To configure the CompactFlash Storage Card in True IDE Mode, the 50-pin socket is power cycled with the CompactFlash Storage Card inserted and -OE (output enable) asserted.

Table 3-31: True IDE Mode I/O Function

| FUNCTION CODE | -CS1 | -CS0 | A0-A2 | -DMACK | -IORD | -IOWR | D15-D8 | D7-D0 |
|-------------------------|------|------|-------|--------|-------|-------|------------------|------------------|
| Invalid Modes | L | L | X | X | X | X | Undefined In/Out | Undefined In/Out |
| | L | X | X | L | L | X | Undefined Out | Undefined Out |
| | L | X | X | L | X | L | Undefined In | Undefined In |
| | X | L | X | L | L | X | Undefined Out | Undefined Out |
| | X | L | X | L | X | L | Undefined In | Undefined In |
| Standby Mode | H | H | X | H | X | X | High Z | High Z |
| Task File Write | H | L | 1-7h | H | H | L | Don't Care | Data In |
| Task File Read | H | L | 1-7h | H | L | H | High Z | Data Out |
| PIO Data Register Write | H | L | 0 | H | H | L | Odd-Byte In | Even-Byte In |
| DMA Data Register Write | H | H | X | L | H | L | Odd-Byte In | Even-Byte In |
| PIO Data Register Read | H | L | 0 | H | L | H | Odd-Byte Out | Even-Byte Out |
| DMA Data Register Read | H | H | X | L | L | H | Odd-Byte Out | Even-Byte Out |
| Control Register Write | L | H | 6h | H | H | L | Don't Care | Control In |
| Alt Status Read | L | H | 6h | H | L | H | High Z | Status Out |
| Drive Address1 | L | H | 7h | H | L | H | High Z | Data Out |

Notes:

- 1) Implemented for backward compatibility. Bit D7 of the register shall remain High Z to prevent conflict with any floppy disk controller at the same address. The host software should not rely on the contents of this register.

3.8 Host Configuration Requirements for Master/Slave or New Timing Modes

The CF Advanced Timing modes include PCMCIA style I/O modes that are faster than the original 250 ns cycle time. These modes are not supported by the PCMCIA specification nor CF by cards based on revisions of the CF specification before Revision 3.0. Hosts shall ensure that all cards accessed through a common electrical interface are capable of operation at the desired, faster than 250 ns, I/O mode before configuring the interface for that I/O mode.

Advanced Timing modes are PCMCIA style I/O modes that are 100 ns or faster, PCMCIA Memory modes that are 100ns or faster, True IDE PIO Modes 5,6 and Multiword DMA Modes 3,4. These modes are permitted to be used only when a single card is present and the host and card are connected directly, without a cable exceeding 0.15m in length. Consequently, the host shall not configure a card into an Advanced Timing Mode if two cards are sharing I/O lines, as in Master/Slave operation, nor if it is constructed such that a cable exceeding 0.15 meters is required to connect the host to the card.

The load presented to the Host by cards supporting Ultra DMA is more controlled than that presented by other CompactFlash cards. Therefore, the use of a card that does not support Ultra DMA in a Master/Slave arrangement with a Ultra DMA card can affect the critical timing of the Ultra DMA transfers. The host shall not configure a card into Ultra DMA mode when a card not supporting Ultra DMA is also present on the same interface

When the use of two cards on an interface is otherwise permitted, the host may use any mode that is supported by both cards, but to achieve maximum performance it should use its highest performance mode that is also supported by both cards.

3.9 Termination Resistors for Ultra DMA Operation

ATP Industrial Grade CF cards provide embedded termination resistors for operation in any of the Ultra DMA modes. The following table describes typical values for series termination at the CF card.

Table 3-2: Termination Resistors for Ultra DMA Operation

| Signal | Termination |
|----------------------------|--------------------|
| -IORD (-HDMARDY, HSTROBE) | 82 ohm |
| -IOWR (STOP) | 82 ohm |
| -CS0, -CS1 | 82 ohm |
| A00, A01, A02 | 82 ohm |
| -DMACK | 82 ohm |
| D15 through D00 | 33 ohm |
| DMARQ | 22 ohm |
| INTRQ | 22 ohm |
| IORDY (-DDMARDY, DSTROBE) | 22 ohm |
| -RESET | 82 ohm |

4 S.M.A.R.T. Function

4.1 S.M.A.R.T. Feature

Self-monitoring analysis and reporting technology (S.M.A.R.T.) is used to protect the user from unscheduled downtime. By monitoring and storing critical performance and calibration parameters, S.M.A.R.T. feature set devices attempt to predict the likelihood of near-term degradation or fault condition. Informing the host system of a negative reliability condition allows the host system to warn the user of the impending risk of a data loss and advise the user of appropriate action.

4.2 S.M.A.R.T. Feature Register Values

In order to select a subcommand the host must write the subcommand code to the device's Features Register before issuing the S.M.A.R.T. Function Set command. The subcommands are listed below.

Table 4-1: S.M.A.R.T. Feature Register Values

| Command | Command Code |
|---------------------------------------|--------------|
| S.M.A.R.T. READ DATA | D0h |
| S.M.A.R.T. READ ATTRIBUTE THRESHOLD | D1h |
| S.M.A.R.T. ENABLE/DISABLE AUTOSAVE | D2h |
| S.M.A.R.T. SAVE ATTRIBUTE VALUES | D3h |
| S.M.A.R.T. EXECUTE OFF-LINE IMMEDIATE | D4h |
| RESERVED | D5h |
| RESERVED | D6h |
| S.M.A.R.T. ENABLE OPERATIONS | D8h |
| S.M.A.R.T. DISABLE OPERATIONS | D9h |
| S.M.A.R.T. RETURN STATUS | DAh |

Note:

If the reserved size is below a threshold, status can be read from the Cylinder Register using the Return Status command (DAh)

4.3 S.M.A.R.T. Data Structure

The following 512 bytes make up the device S.M.A.R.T. data structure. Users can obtain the data using the “Read Data” command (D0h).

Table 4-2: S.M.A.R.T. Data Structure

| Byte | F/V | Description |
|---------|-----|--|
| 0~1 | X | Revision code |
| 115~116 | V | Power Cycle count of the device |
| 362 | V | Off-line data collection status |
| 363 | X | Self-test execution status byte |
| 364~365 | V | Total time in seconds to complete off-line data collection activity |
| 367 | F | Off-line data collection capability |
| 368~369 | F | S.M.A.R.T. capability |
| 370 | F | Error logging capability: 7-1 Reserved 0 1 = Device error logging supported |
| 372 | F | Short self-test routine recommended polling time(in minutes) |
| 373 | F | Extended self-test routine recommended polling time(in minutes) |
| 374 | F | Conveyance self-test routine recommended polling time(in minutes) |
| 375~385 | R | Reserved |
| 386~395 | F | Firmware Version/Date Code |
| 396~397 | F | Number of initial invalid block (396=MSB, 397=LSB) |
| 398~399 | V | Number of run time bad block (398=MSB, 399=LSB) |
| 400 | V | Number of spare block |
| 401~402 | V | Erase count (Low word. The value is identical to that of Byte 409~410) |
| 403~405 | F | ‘SMI’ |
| 406 | F | Number of max pair |
| 407~410 | V | Erase count (407~408 =High word, 409~410 =Low word) |
| 511 | V | Data structure checksum |

Notes:

F=content (byte) is fixed and does not change

V=content (byte) is variable and maybe change depending on the state of the device or the command executed by the device

X= content (byte) is vendor specific and maybe fixed or variable

R=content (byte) is reserved and shall be zero

N=Nth Management Unit

*4 Byte value: [MSB][2][1][LSB]

4.4 ATP S.M.A.R.T. Tool

ATP provides S.M.A.R.T. Tool for Windows 2000/XP/Vista/7 and Linux, It can monitor the state of Industrial Grad CompactFlash, and the following picture shows S.M.A.R.T. tool operation. This tool supports that users read spare and bad block information. Users can thus evaluate drive health at run time and receive an early warning before the drive life ends.

Figure 4-1: ATP S.M.A.R.T. tool operation

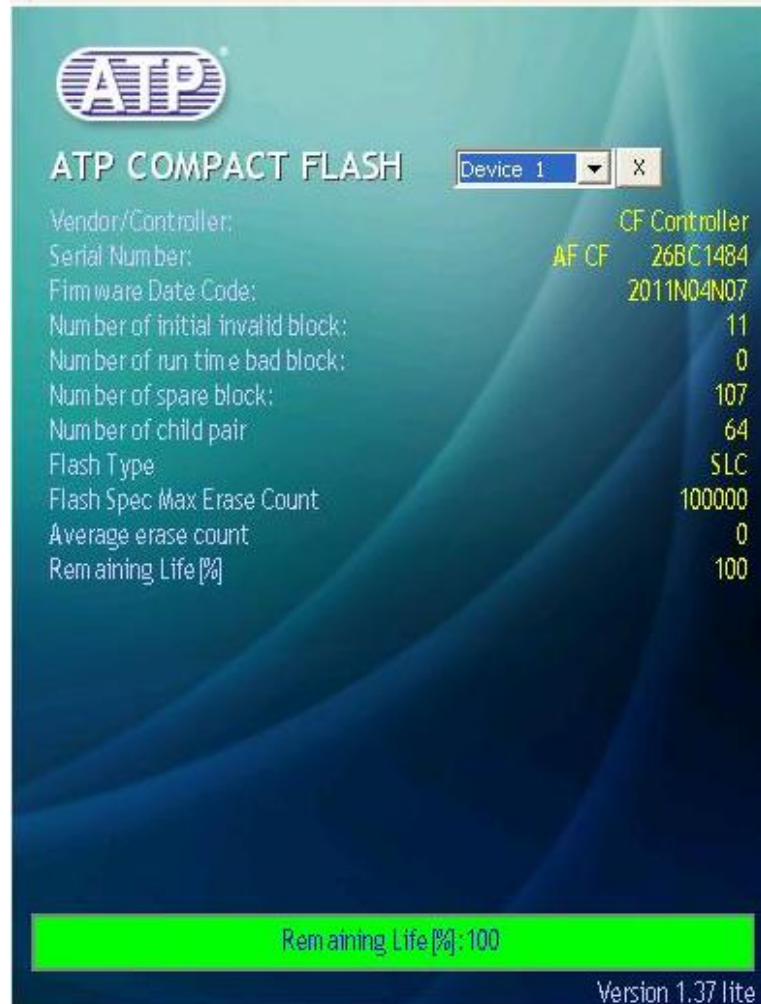

ATP Electronics Inc.
 TEL: +1-408-732-5000
 FAX: +1-408-732-5055
 sales@atpinc.com
 750 North Mary Ave. Sunnyvale,
 CA 94085 USA

ATP Electronics Europe B.V.
 TEL: +31-88-287-0000
 FAX: +31-88-287-0099
 sales-europe@atpinc.com
 Corkstraat 46, Rotterdam 3047 AC,
 The Netherlands

ATP Electronics Tokyo Office
 TEL: +81-03-6206-8097
 FAX: +81-03-6206-8098
 sales-japan@atpinc.com
 www.atpinc.co.jp
 #1007, 10F, 1-8-4 Kandasakuma-cho,
 Chiyoda-ku, Tokyo

ATP Electronics (Shanghai), Inc.
 TEL: +86-21-5080-2220
 FAX: +86-21-5080-2219
 sales@cn.atpinc.com
 www.atpinc.com.cn
 Room 102, No.500 BiBo road,
 Zhangjiang High-tech park, Shanghai,
 China, 201203